



Decarbonizing Existing Buildings



Mark LaFrance

HTS New England

Rick Stehmeyer

Control Technologies Inc. (CTI)





Mark LaFrance

HTS New England

University of New Hampshire - Mechanical Engineer

Core role at HTS is supporting Consulting Engineers with HVAC equipment applications

Likes long walks at HVAC trade shows, and cars



Rick Stehmeyer

Control Technologies Inc. (CTI)

St. Michael's College – Computer Science

Core role at CTI is Corporate Strategist, directing CTI on product development and business strategies

Likes science, technology, sci-fi, and music

Agenda

- **Part 1 – Introduction / Background**
- Part 2 – Reducing Heating Loads
- Part 3 – Electrifying Heating Systems
- Part 4 – Reducing Fan Energy
- Part 5 – The Importance of Intelligent Building Controls

Decarbonization

Reduction or elimination of carbon dioxide emissions

What role do buildings play?

Approximately **30%** of carbon dioxide emissions come from buildings

- Emissions from consumption *on-site* at buildings
- Emissions from power generation

Economic Driving Forces

- Uncle Sam vs. Market Forces

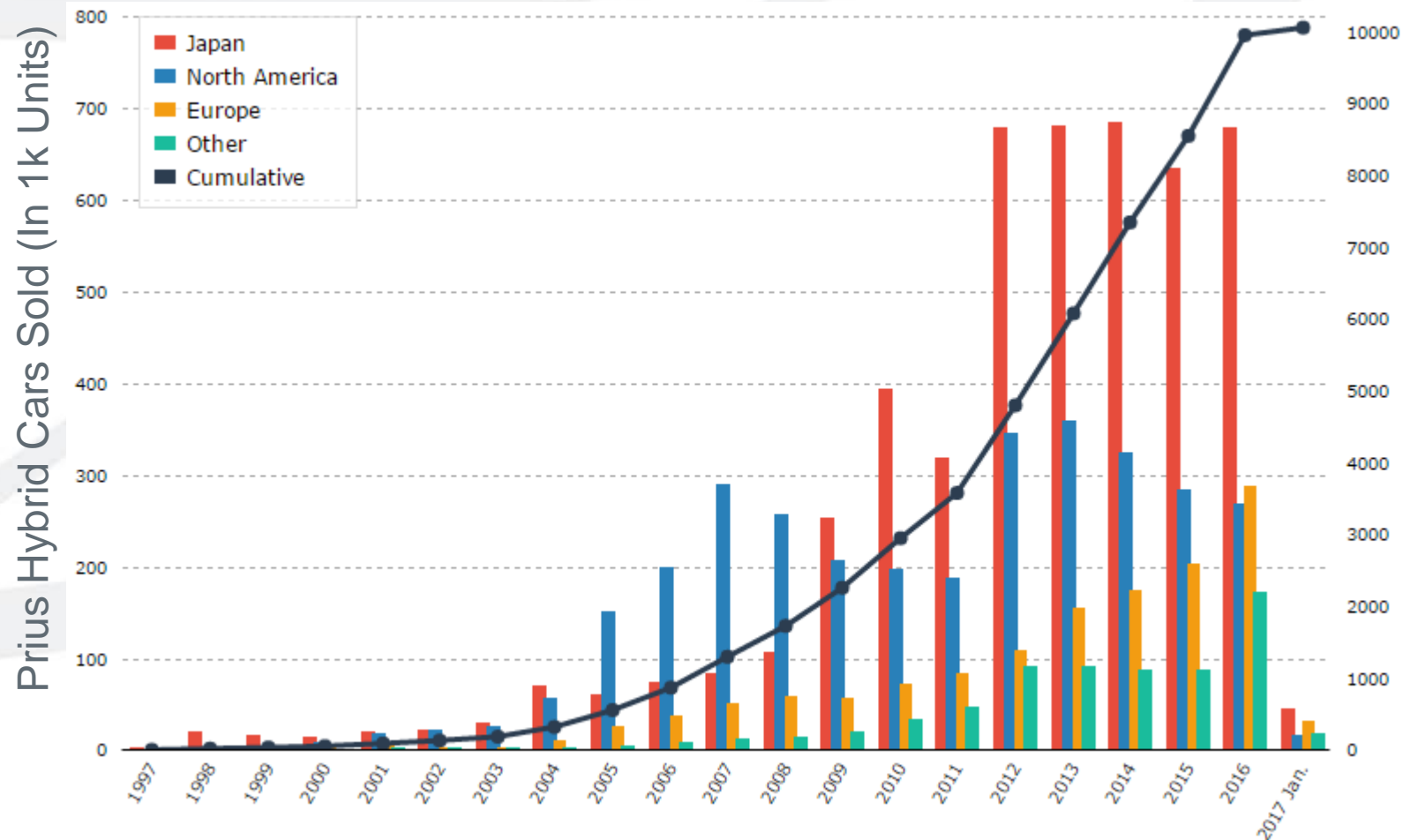

Source: <https://global.toyota/en/detail/14940871>

Start with a recent research project:

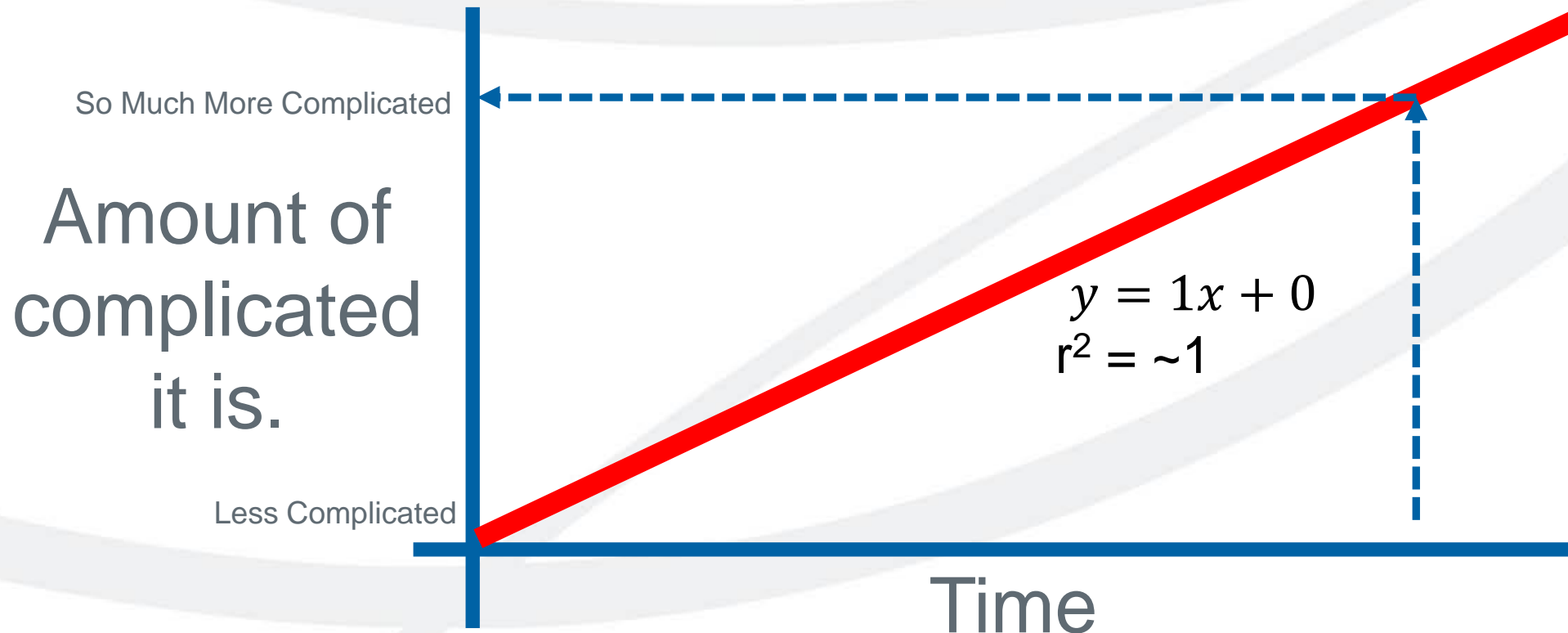

Why are we talking about this?

and because we all collectively are just not doing enough.

Atmospheric CO₂ at Mauna Loa Observatory

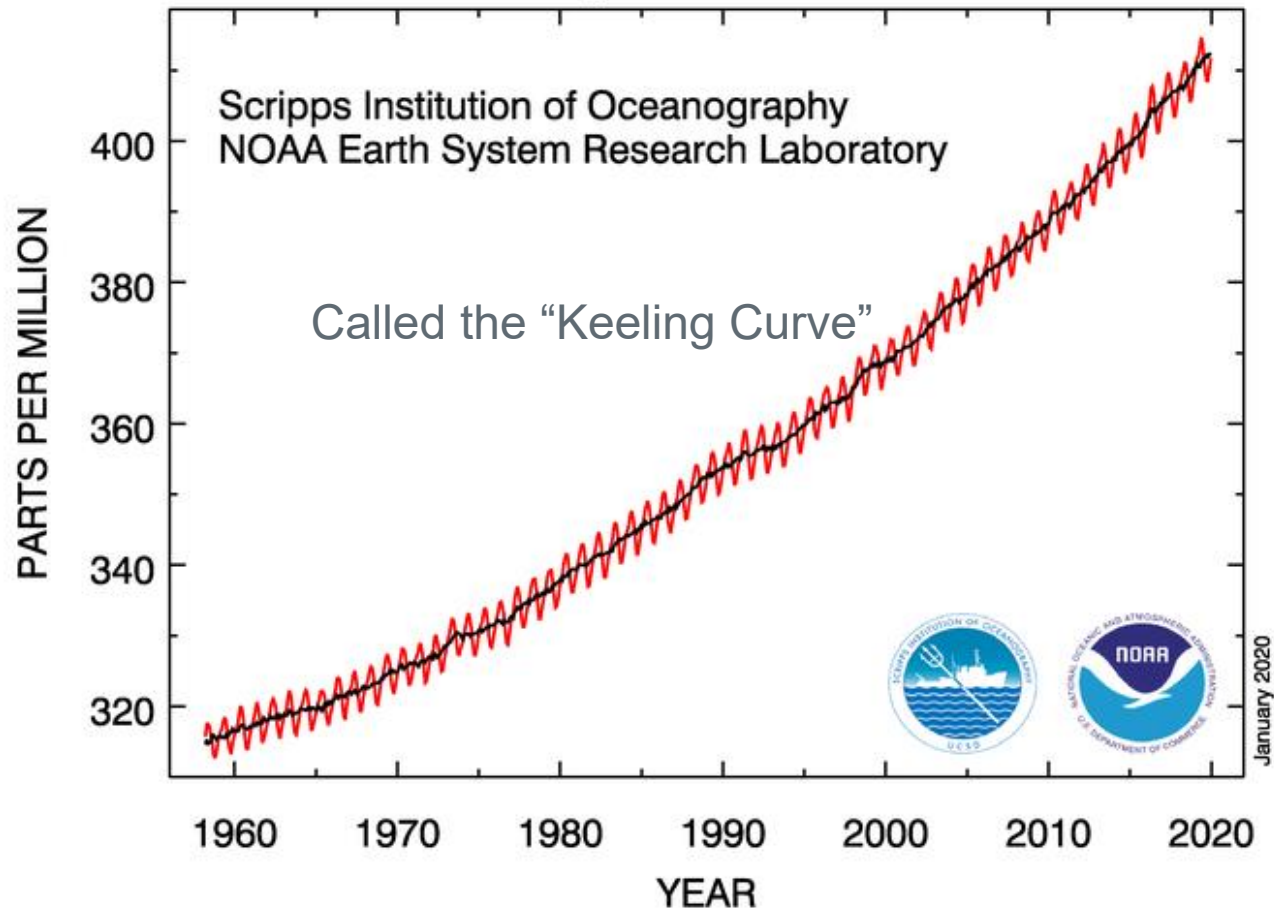

Global fossil fuel consumption

Measured in terawatt-hours of primary energy consumption.

Table

Chart

Our World
in Data

Settings

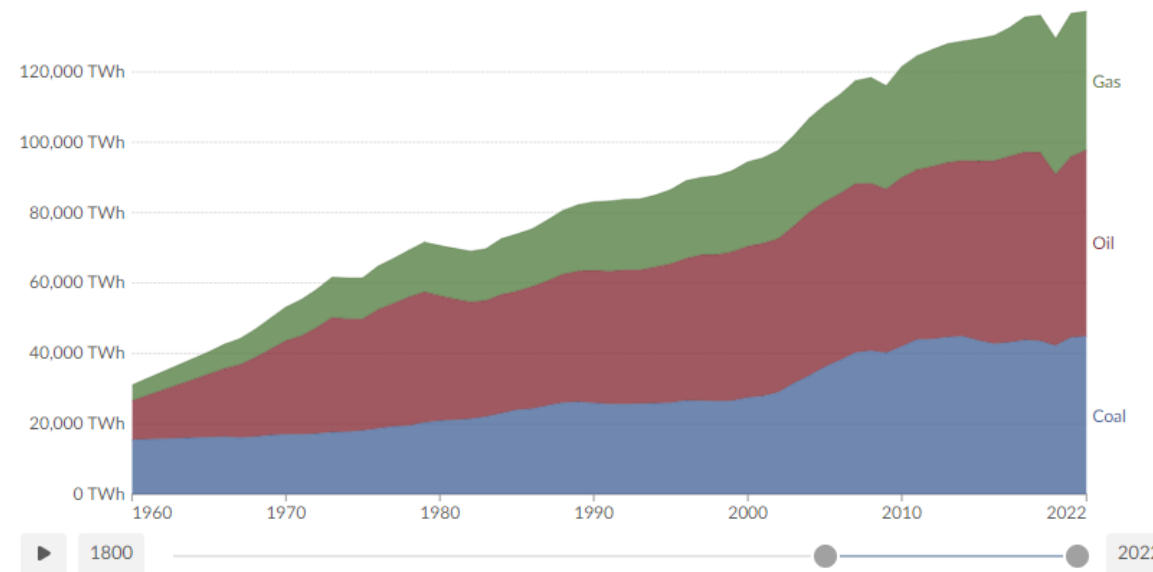

Data source: Energy Institute - Statistical Review of World Energy (2023); Smil (2017) - [Learn more about this data](#)

OurWorldInData.org/fossil-fuels | CC BY



An important measurement

11,135ft Elevation

On the Ocean side of our planet, no emission sources nearby

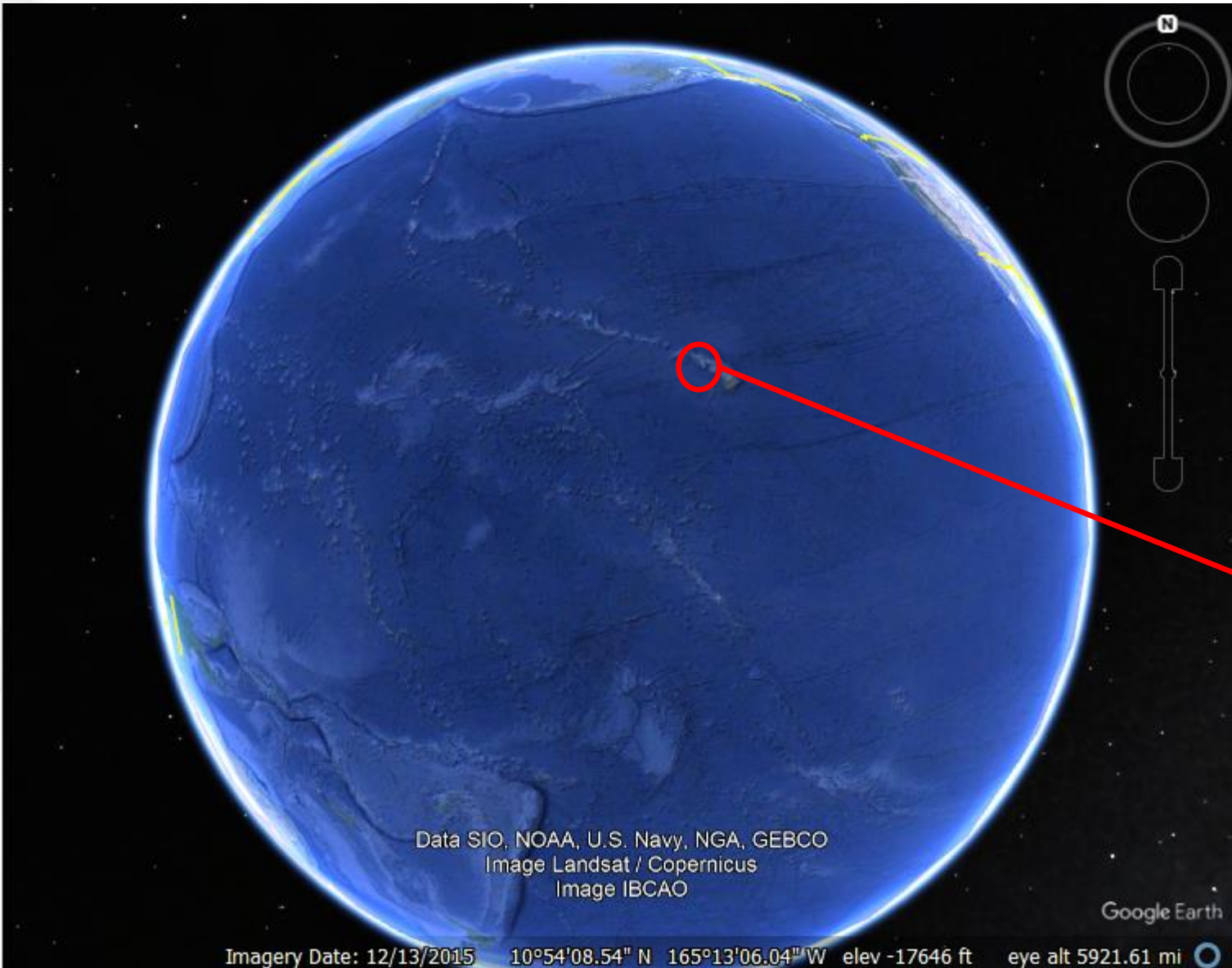

The data from the measurement modeled against historical data

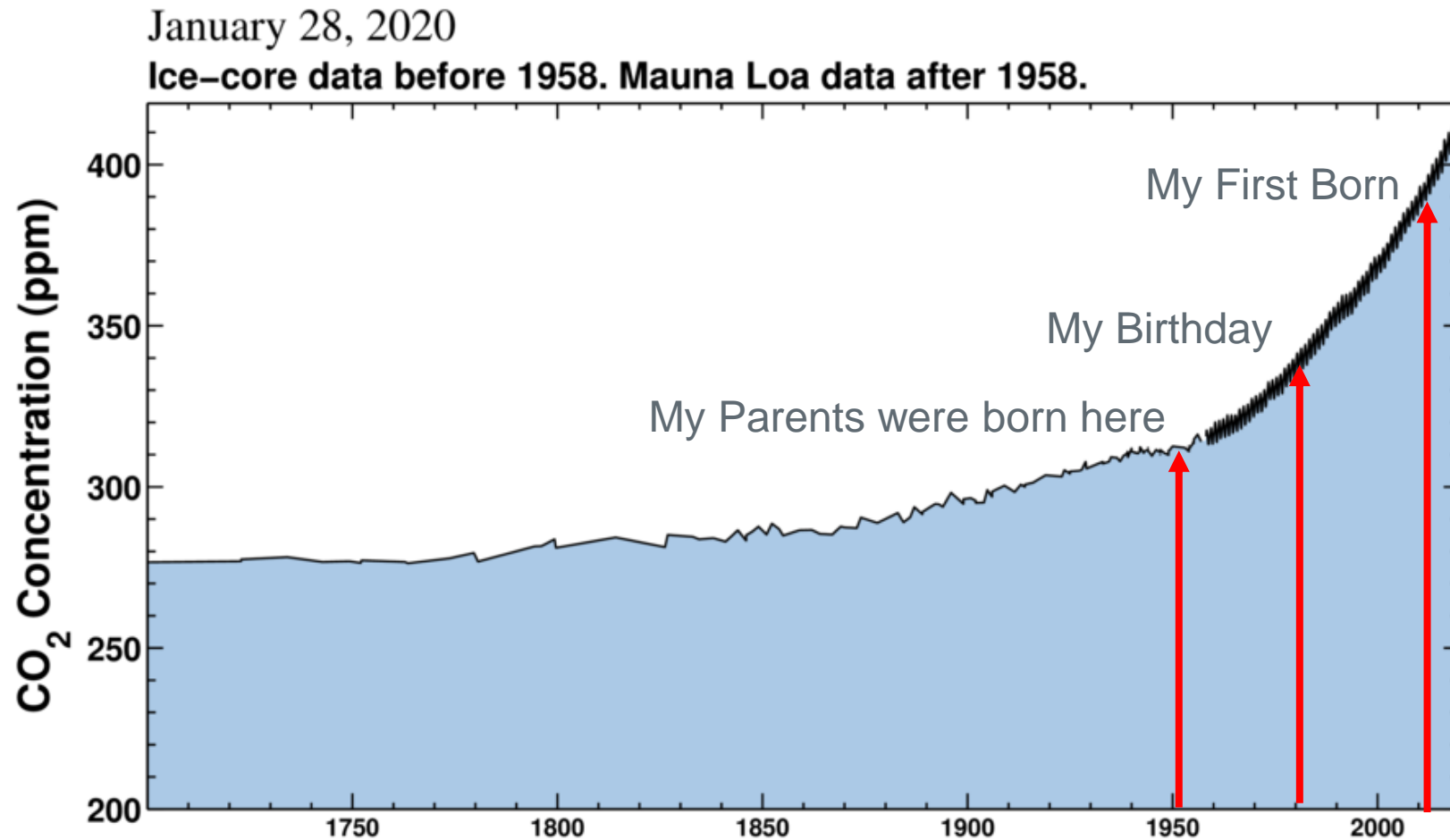

Energy Data measured by the EPA

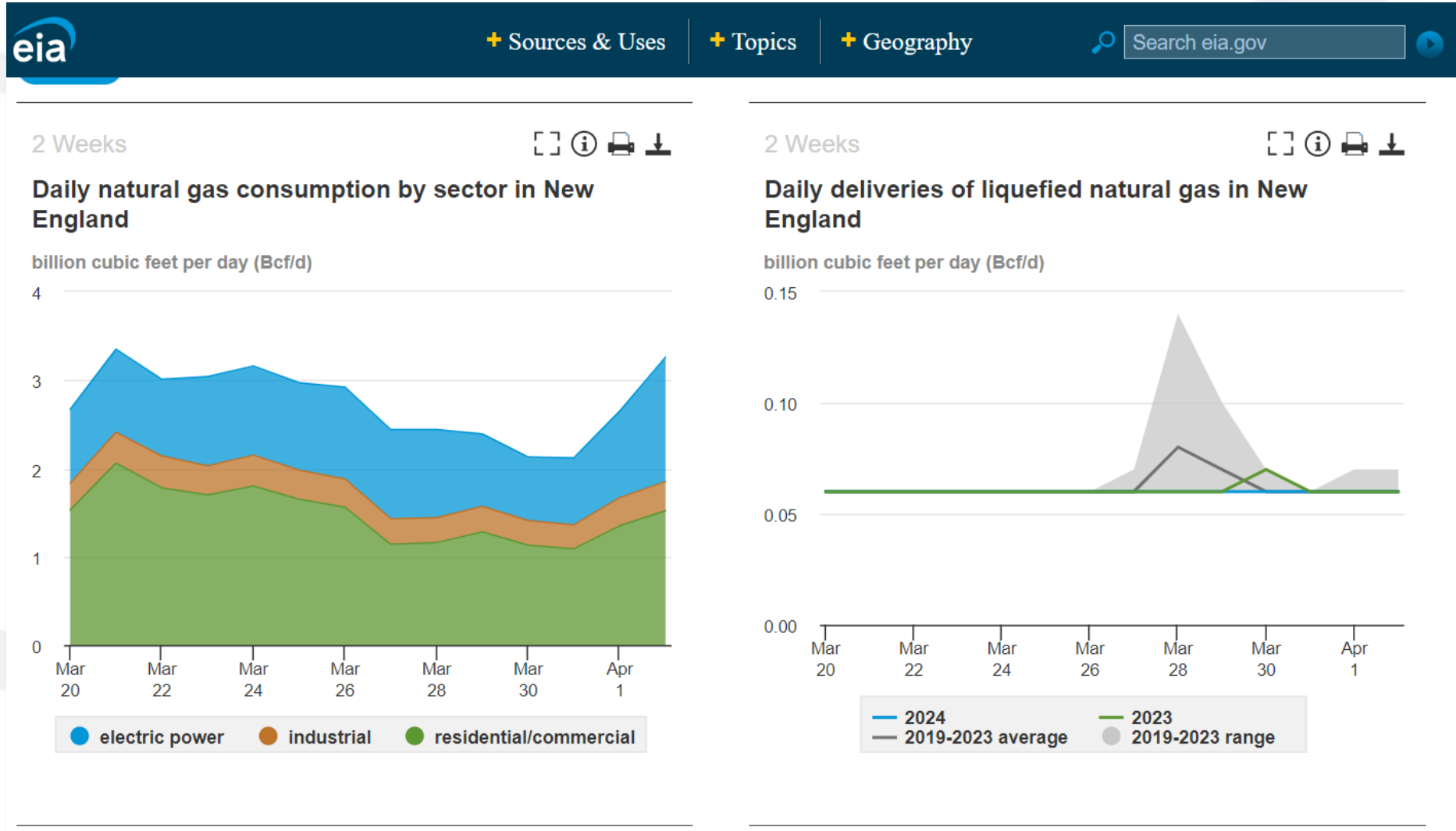

Calm down Carl. We're c

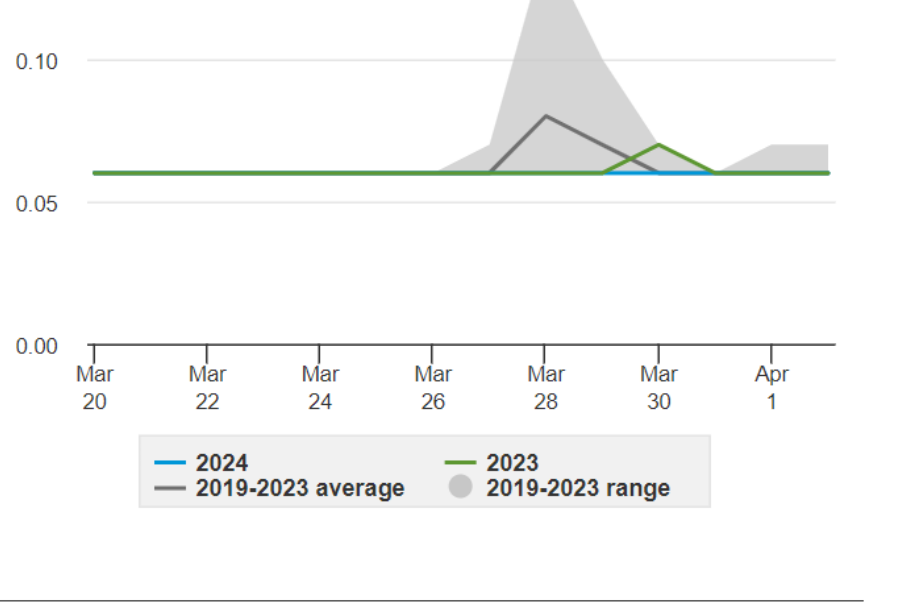
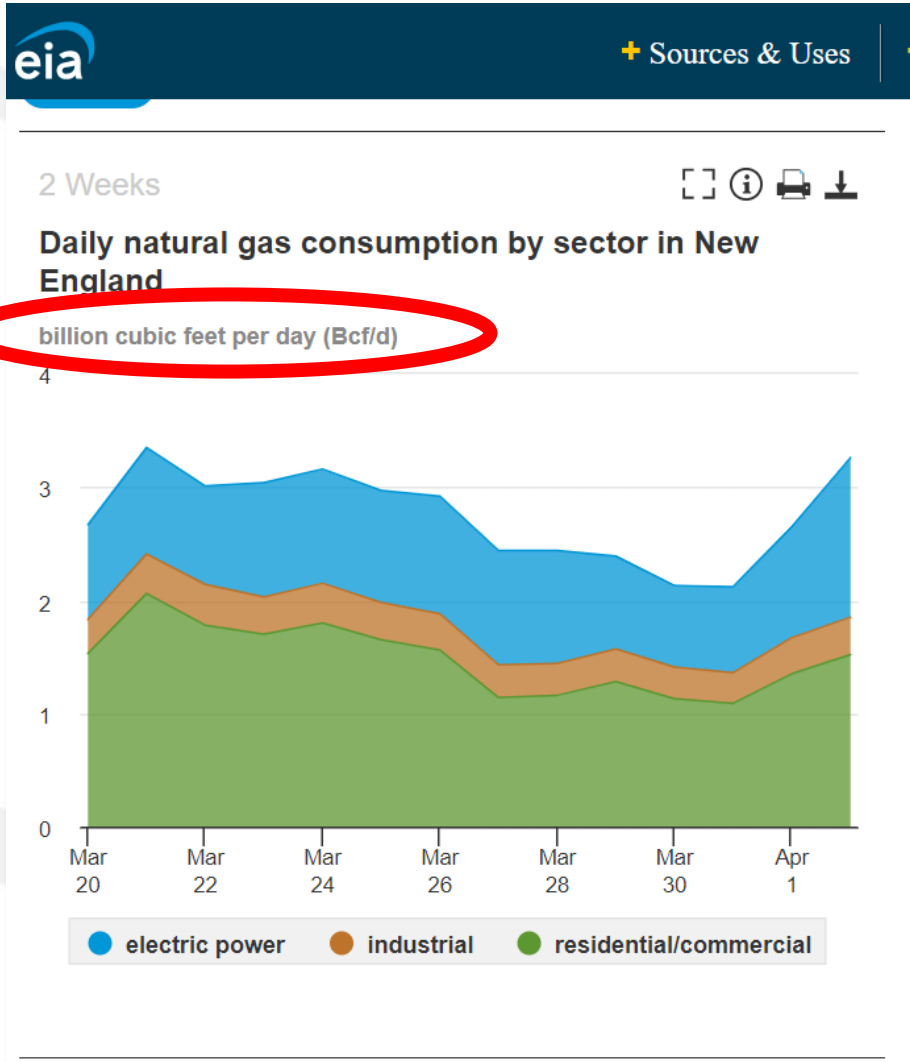

Where do we start? Measure the problem

ENERGY.GOV Newsroom Careers Energy.gov Offices National Labs Search Energy.gov

Office of ENERGY EFFICIENCY & RENEWABLE ENERGY ABOUT EERE RESOURCES BUILDINGS & INDUSTRY RENEWABLE ENERGY SUSTAINABLE TRANSPORTATION

Decarbonizing the U.S. Economy by 2050: A National Blueprint for the Buildings Sector

Office of Energy Efficiency & Renewable Energy

Office of Energy Efficiency & Renewable Energy »
Decarbonizing the U.S. Economy by 2050: A National Blueprint for the Buildings Sector

The U.S. Department of Energy led the development of a Blueprint for decarbonizing U.S. buildings by 2050 to lay out a national strategy for aggressively reducing building greenhouse gas emissions while delivering equity, affordability, and resilience benefits to communities. The vision includes action the federal government can take to meet specific targets for increasing building energy efficiency, accelerating onsite emissions reductions, transforming the grid edge, and minimizing embodied life cycle emissions.

The national strategy reflects the central role that buildings play in achieving economy-wide climate goals.

- Increase building energy efficiency**
- Accelerate onsite emissions reductions**
- Transform the grid edge**
- Minimize embodied life cycle emissions**

Lots of Low Hanging Fruit



CALENDAR LIBRARY CAREERS

About Us Participate Committees and Groups System Planning Market

Reliable Electricity. Competitive Prices. Clean-Energy Transition. [OUR MISSION](#)

Price Map

REAL TIME DAY AHEAD

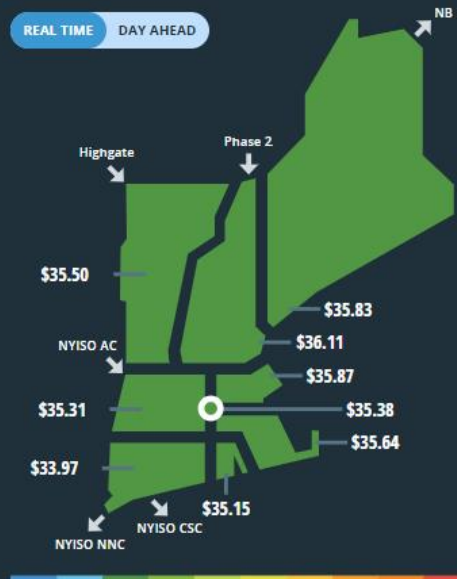

Resource Mix

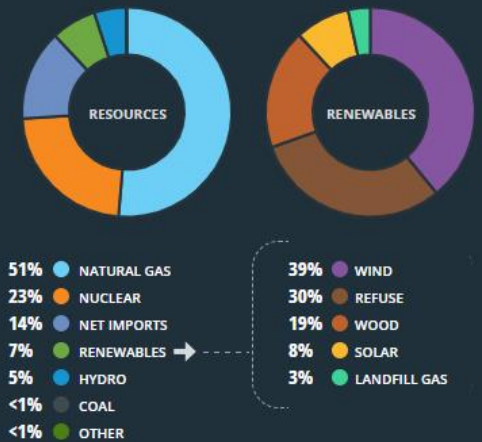

System Demand



System Status

Today's Snapshot
AS OF 02/09/2024 07:36 AM

20,629	15,050	3,276	15,749
AVAILABLE CAPACITY (MW)	FORECASTED PEAK DEMAND (MW)	SURPLUS CAPACITY (MW)	YESTERDAY'S PEAK DEMAND (MW)

Resource Mix

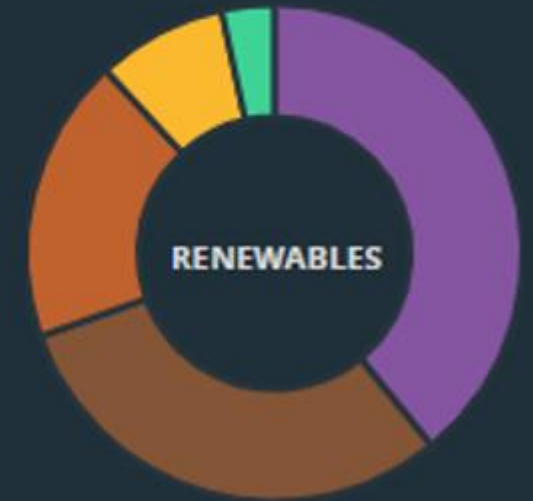

- 51% NATURAL GAS
- 23% NUCLEAR
- 14% NET IMPORTS
- 7% RENEWABLES
- 5% HYDRO
- <1% COAL
- <1% OTHER

- 39% WIND
- 30% REFUSE
- 19% WOOD
- 8% SOLAR
- 3% LANDFILL GAS

Where do we start? Measure the problem



CITY of **BOSTON**

Mayor Michelle Wu



INFORMATION AND SERVICES

PUBLIC NOTICES

FEEDBACK

ENGLISH



[HOME](#) › [DEPARTMENTS](#) › [ENVIRONMENT](#) › [BUILDING EMISSIONS REDUCTION AND DISCLOSURE](#)

Last updated: 3/28/24

BUILDING EMISSIONS REDUCTION AND DISCLOSURE

Boston's Building Emissions Reduction and Disclosure Ordinance (BERDO) sets requirements for large existing buildings to reduce their greenhouse gas emissions over time.

FOR REPORTING QUESTIONS:

Email or call Monday through Friday, from 9 a.m. - 5 p.m.



ENERGYREPORTING@BOSTON.GOV



617-635-3850 X5

[RETROFIT RESOURCE HUB WEBSITE](#)

[BERDO REVIEW BOARD WEBSITE](#)

[BERDO REGULATIONS WEBSITE](#)

BERDO – Size and Scope of Impact

Table 1: BERDO Emissions Compliance Years

Non-Residential	Residential	Emissions Compliance Year
35,000 ft ² or larger	35 + units	2025
20,000 - 34,999 ft ²	15 - 34 units	2030

Building Type	Number of Buildings
Commercial	4,184
Industrial	307
Public & Quasi-Public	2,347
Residential	75,856
Residential (Mixed-Use)	1,693

~8,500 buildings the classifications shown on this slide that will likely have to act because of BERDO

Building Area	Number of buildings			
	Industrial	Commercial	Public & Quasi-Public	Residential (Mixed-Use)
< 25,000 sqft	230	3,426	1,579	1,463
25,000-34,999 sqft	21	178	168	49
35,000-49,999 sqft	19	134	140	41
50,000-99,999 sqft	23	202	212	61
>= 100,000 sqft	14	244	248	79

Year Built Class	Number of buildings			
	Industrial	Commercial	Public & Quasi-Public	Residential (Mixed-Use)
1980-present	43	465	448	467
1950-1979	66	596	189	52
1915-1949	125	1,816	430	451
Pre-1915	73	1,307	1,280	723

BERDO Emissions Standards over time

BERDO Emissions Standards

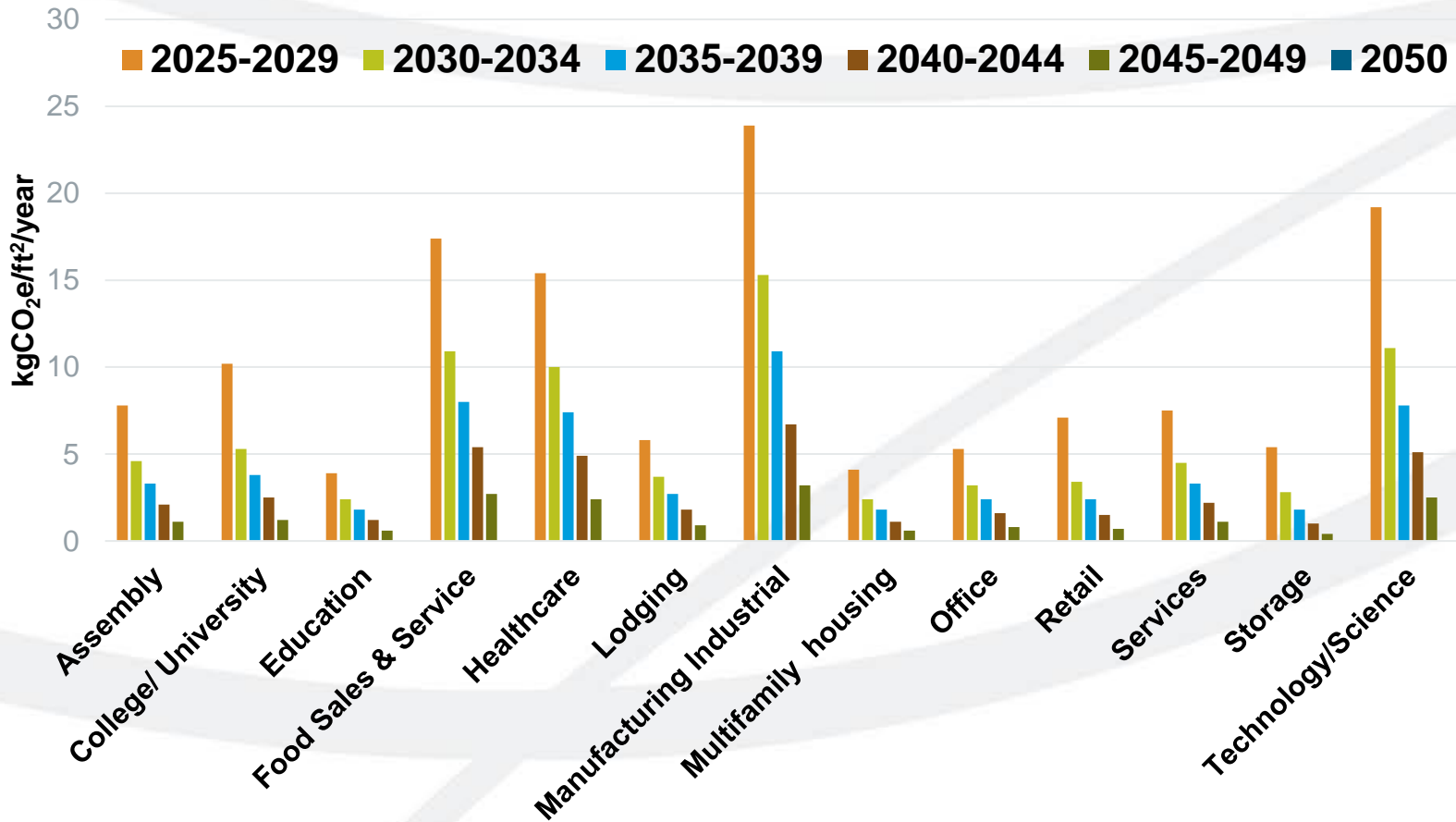

Building Type and Emissions Standards over time

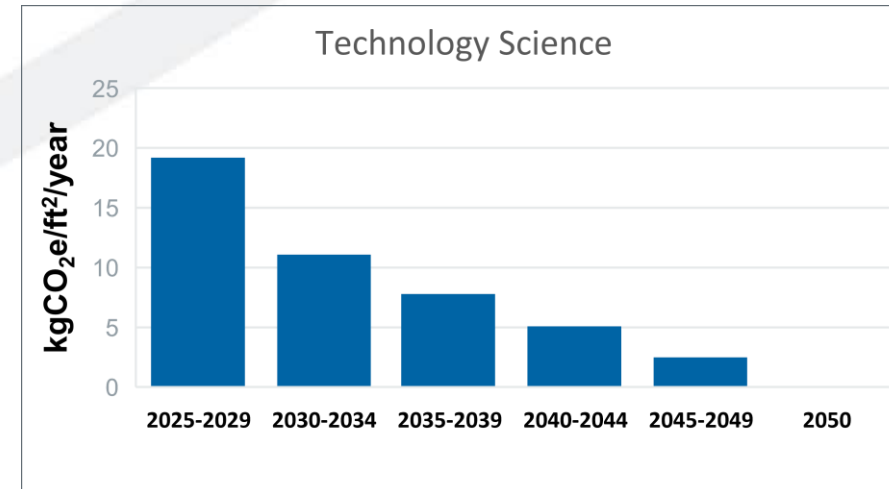
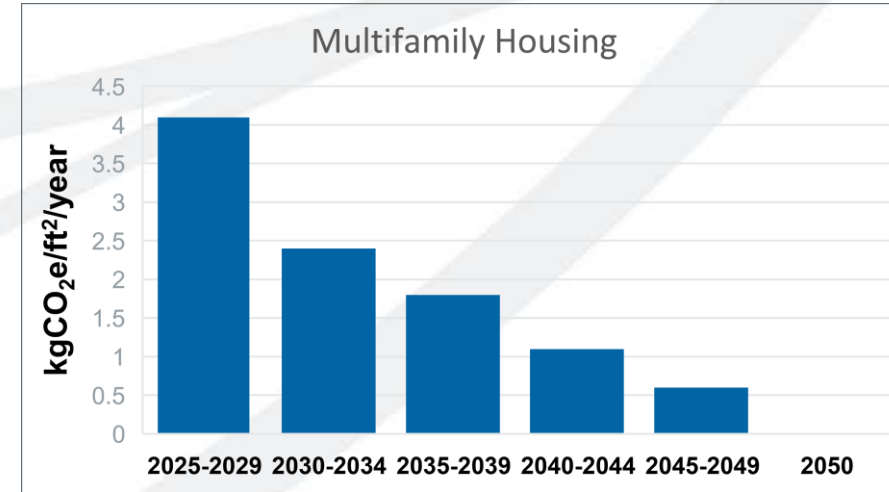

Two-pronged approach

Energy Consumption needs to decrease.

Grid CO₂/kWh needs to decrease

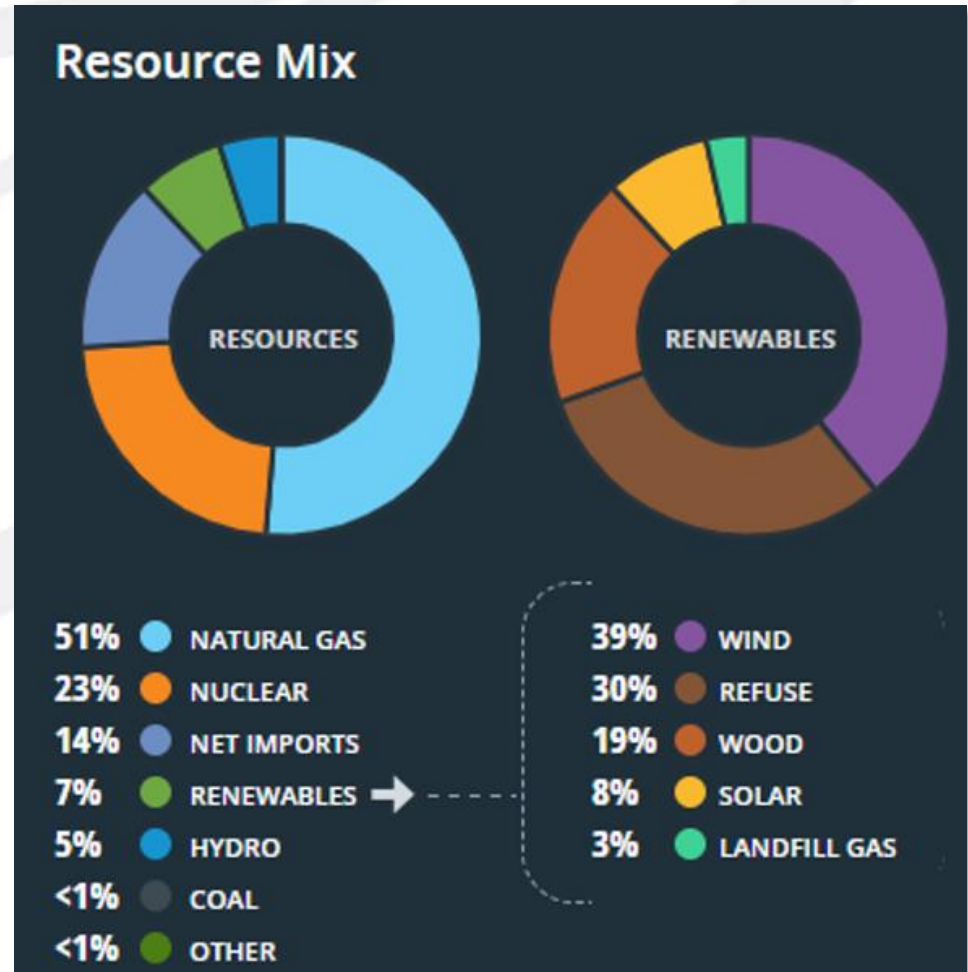
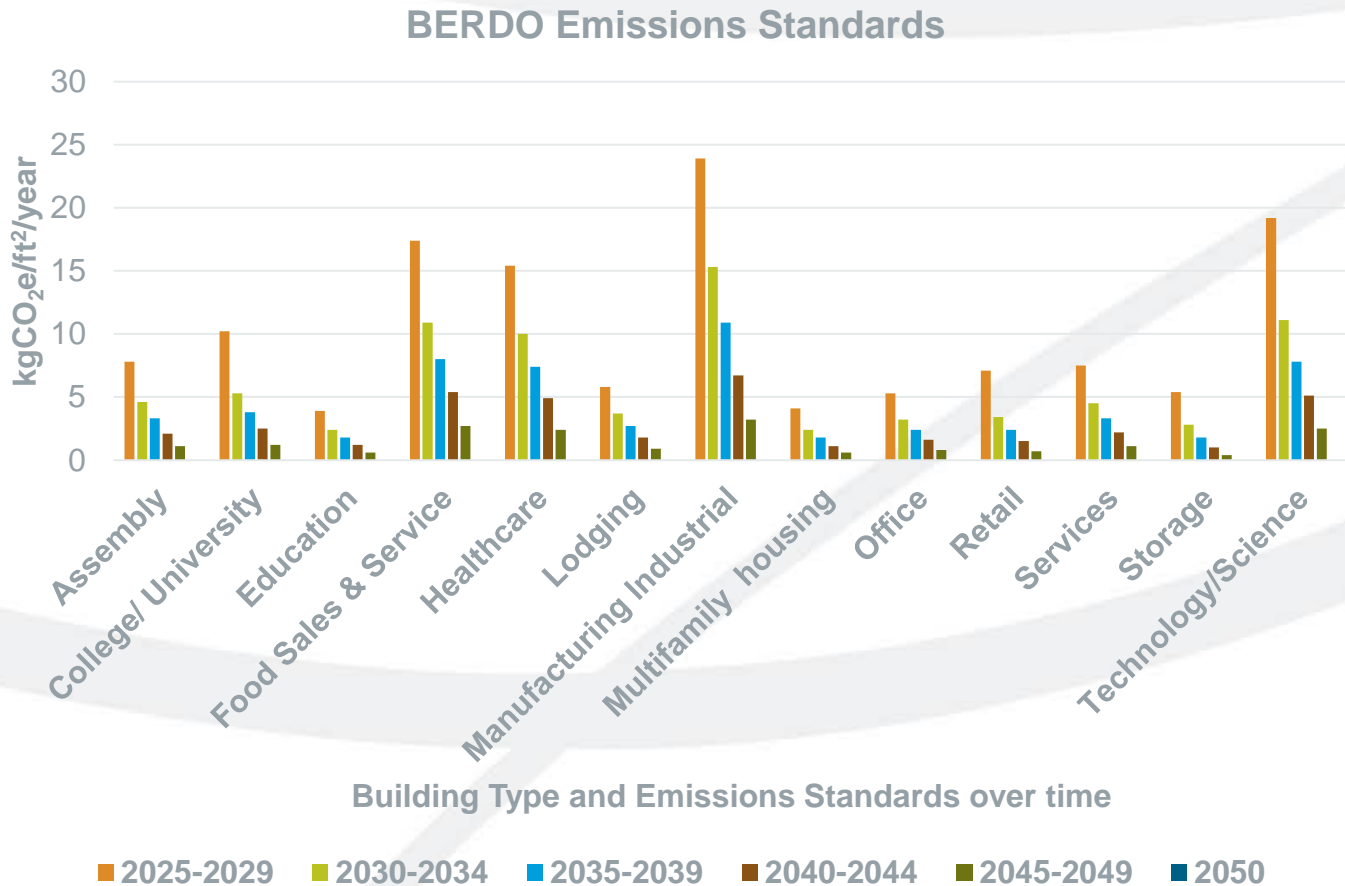

Decarbonizing Existing Buildings

80% of the predicted building stock for 2050 are buildings that exist today

These exist today!

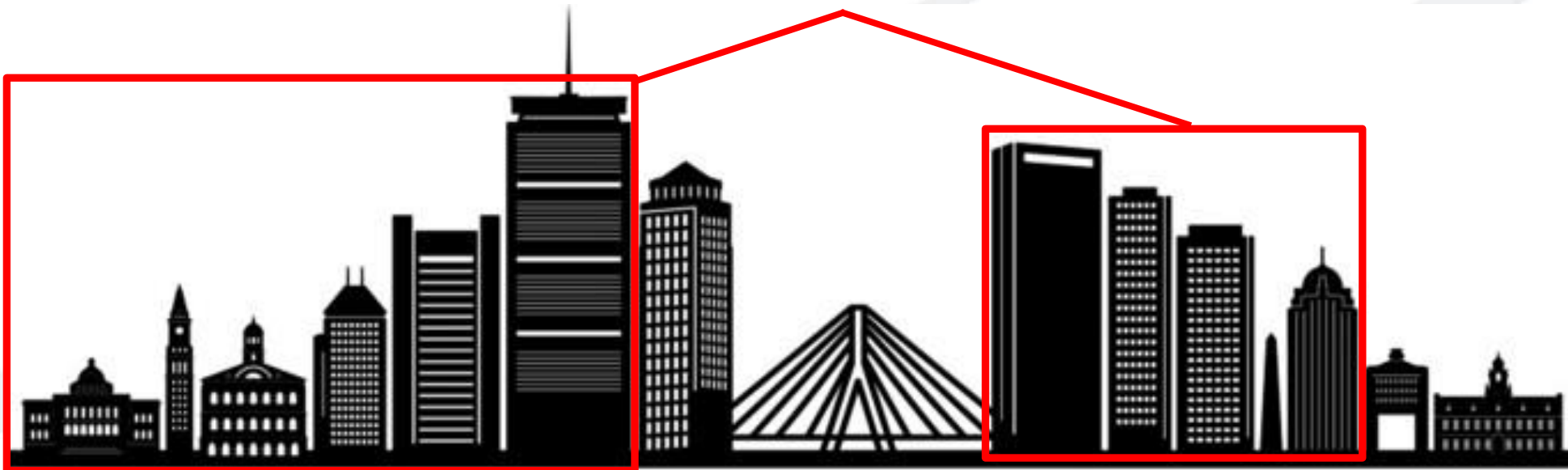

Circa 2050

Your existing largest loads are likely HVAC

Decarbonization requires a focus on Mechanical Equipment upgrades and Controls

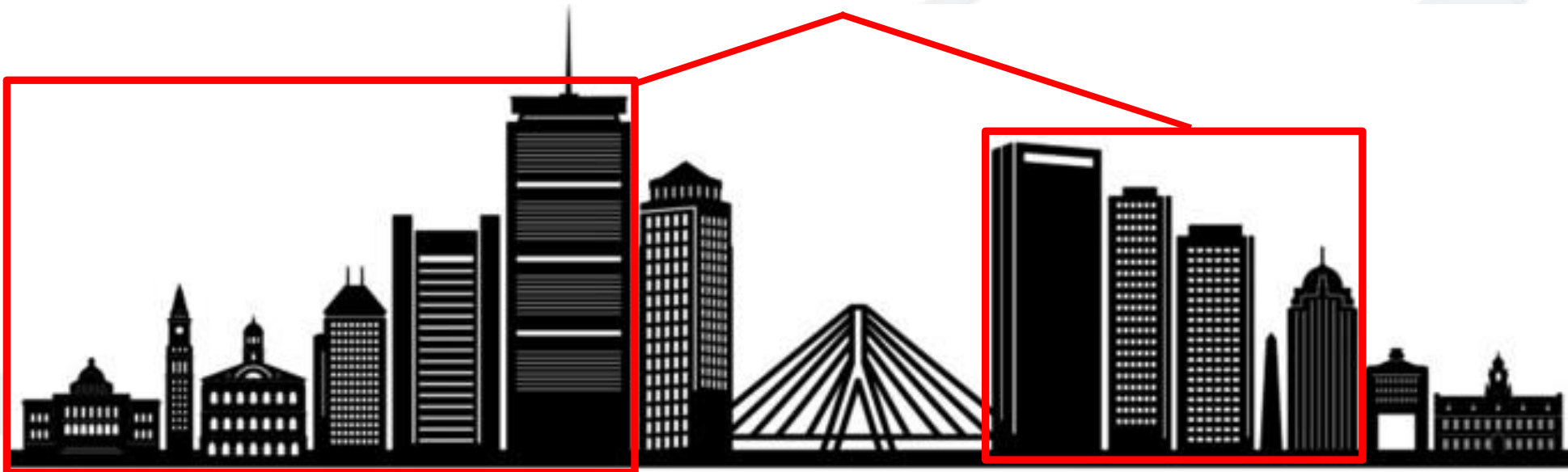

Decarbonization Pathway

Figure 55. Commercial Final Energy Demand by End Use, Electrification Pathway (left) and Deep Retrofit Pathway (right).

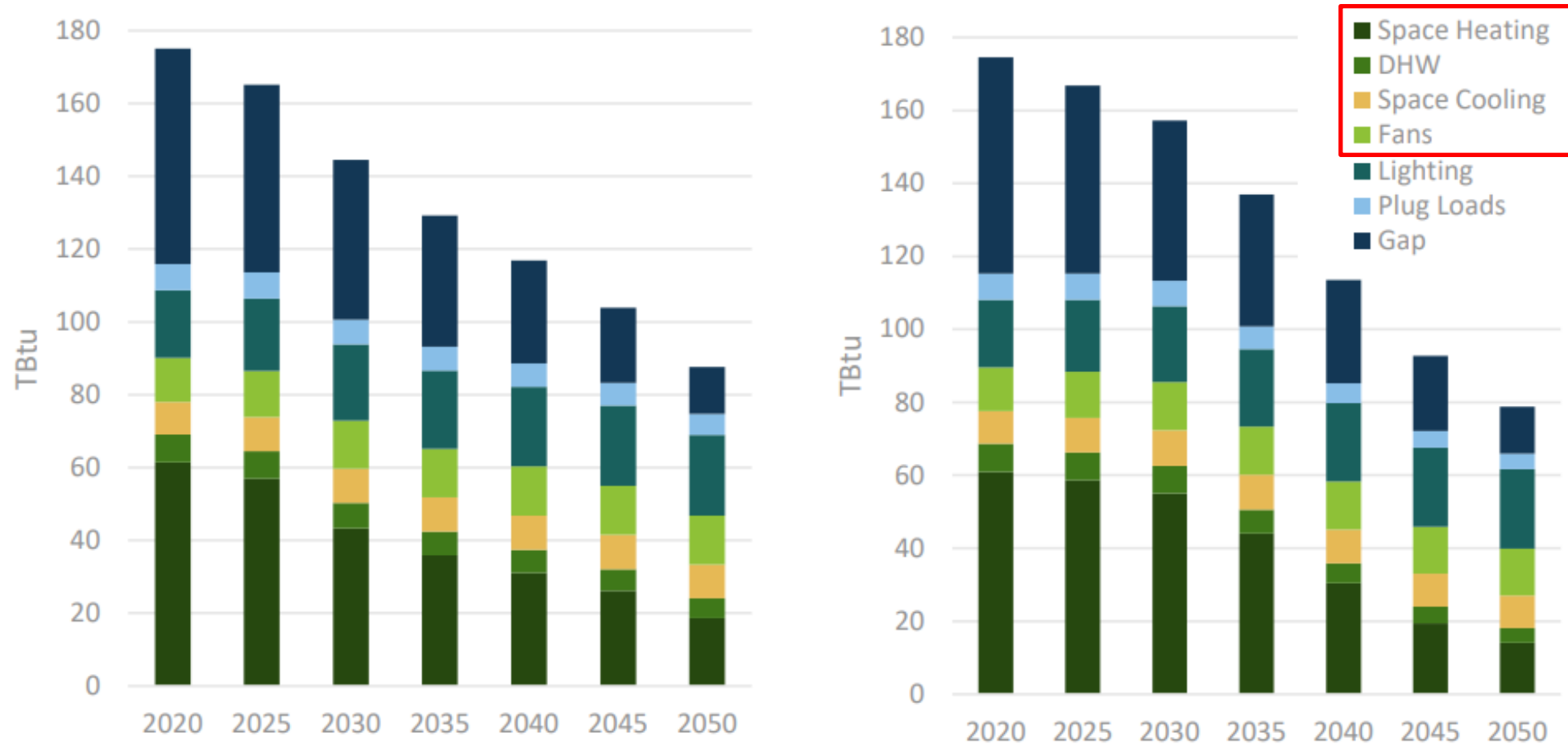

Decarbonization Pathway

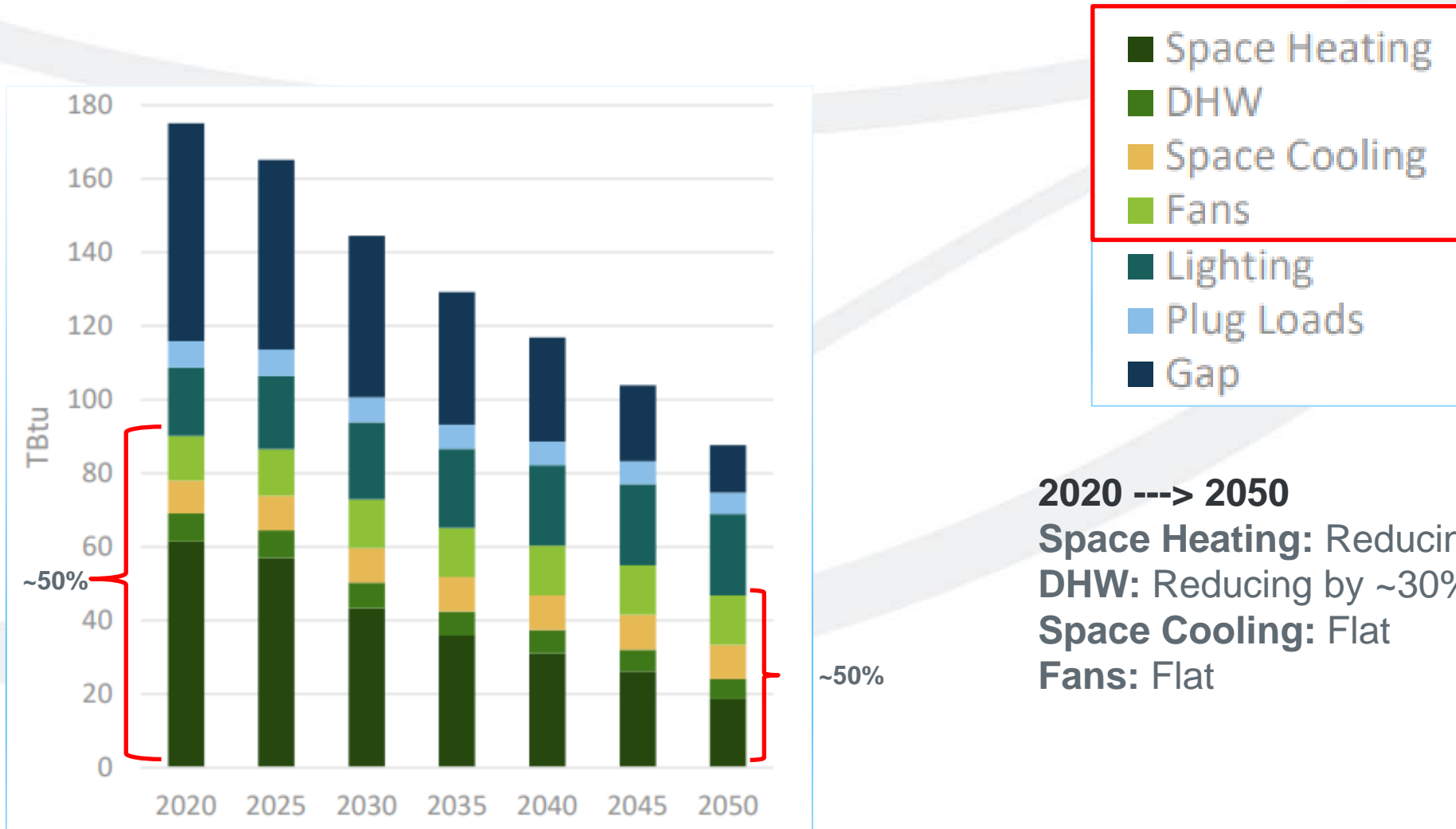

2020 ----> 2050

Space Heating: Reducing by ~70%

DHW: Reducing by ~30%

Space Cooling: Flat

Fans: Flat

Space Heating Energy Reduction

- Space Heating
- DHW
- Space Cooling
- Fans

- How do we **reduce** heat loads required for the mechanical design?
- Where can we **recover** heat from to reduce the generation of *new* heat?

Domestic Hot Water Energy Reduction

- Space Heating
- DHW
- Space Cooling
- Fans

- Are we using energy to heat water while other mechanical equipment is rejecting heat?
- Where can we **recover** heat to generate DHW?

Space Cooling Energy Reduction

- Space Heating
- DHW
- Space Cooling
- Fans

- How do we **reduce** cooling loads required for the mechanical design?
- Can we reject heat to a source where heat is needed?

Fan Energy Reduction

- Space Heating
- DHW
- Space Cooling
- Fans

- **Are we paying attention to fan energy consumption?**

What's our role here!?

- We are experts in building mechanical systems
- The world is counting on **US** to help address this issue!
- **We need to:**
 - **Reduce** demand/load at the buildings
 - › **Reduce** emissions at the building
 - › **Reduce** the load we are putting on the grid

Agenda

- Part 1 – Introduction / Background
- **Part 2 – Reducing Heating Loads**
- Part 3 – Electrifying Heating Systems
- Part 4 – Reducing Fan Energy
- Part 5 – The Importance of Intelligent Building Controls

What are we heating?

- Ventilation air
- Building from envelope losses
- Domestic hot water

How much of heating energy is ventilation?

The 40-40-40 Rule

Ventilation energy reduction is the lowest hanging fruit in building decarbonization

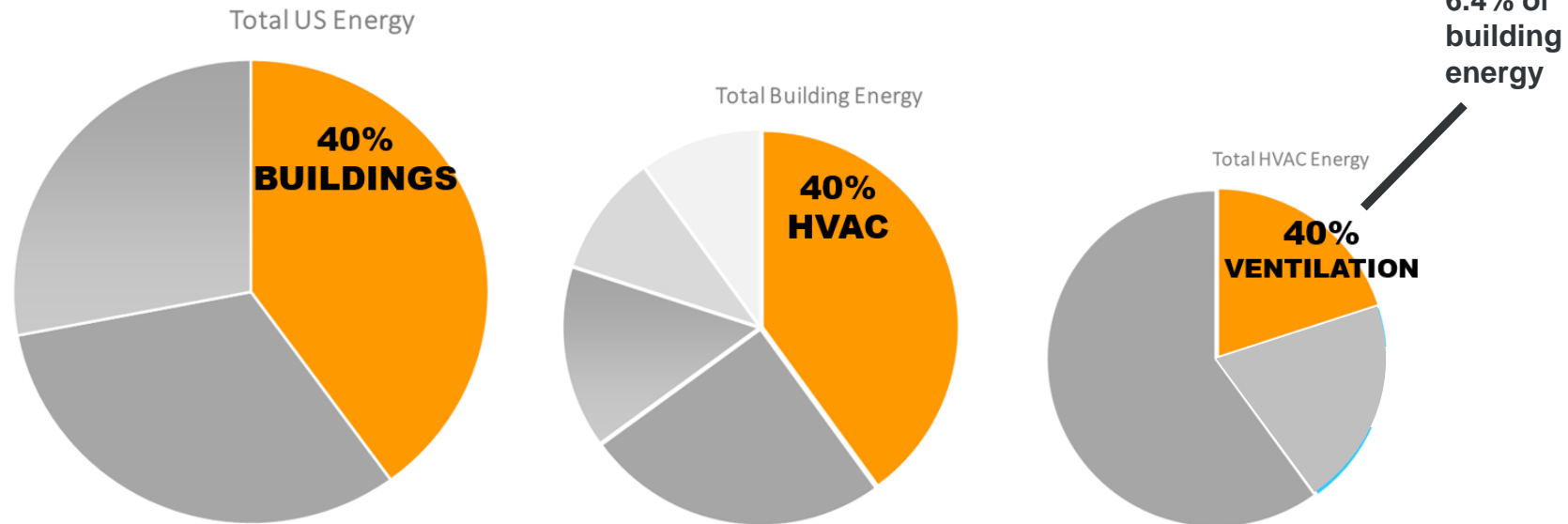

What is ASHRAE Standard 62.1?



ANSI/ASHRAE Standard 62.1-2022
(Supersedes ANSI/ASHRAE Standard 62.1-2019)
Includes ANSI/ASHRAE addenda listed in Appendix Q

Ventilation and Acceptable Indoor Air Quality

See Appendix Q for approval dates by ASHRAE and the American National Standards Institute.

This Standard is under continuous maintenance by a Standing Standard Project Committee (SSPC) for which the Standards Committee has established a documented program for regular publication of addenda or revisions, including procedures for timely, documented, consensus action on requests for change to any part of the Standard. Instructions for how to submit a change can be found on the ASHRAE® website (www.ashrae.org/continuous-maintenance).

The latest edition of an ASHRAE Standard may be purchased from the ASHRAE website (www.ashrae.org) or from ASHRAE Customer Service, 180 Technology Parkway, Peachtree Corners, GA 30092. E-mail: orders@ashrae.org. Fax: 678-539-2129. Telephone: 404-636-8400 (worldwide), or toll free 1-800-527-4723 (for orders in US and Canada). For reprint permission, go to www.ashrae.org/permissions.

© 2022 ASHRAE ISSN 1041-2336



PDF includes hyperlinks for convenient navigation. Click on a reference to a section, table, figure, or equation to jump to its location. Return to the previous page via the bookmark menu.



Standard 62.1 specifies **minimum ventilation rates** and other measures intended to provide indoor air quality (IAQ) **that is acceptable to human occupants and that minimizes adverse health effects.**

Applies to all commercial applications except critical care healthcare (see ASHRAE Standard 170) and laboratories with hazardous materials.

Latest version is 62.1-2022 (Released September 30th, 2022)

The **Ventilation Rate Procedure (VRP)** prescribes the quantity of outdoor air that must be delivered to each zone, based on the expected use of that zone, and then prescribes how to calculate the outdoor airflow needed at the system-level intake.

62.1-2022 Addendum c: ASHRAE IAQP Calculator

“This proposed addendum provides a calculator for mass balance equations used with the revised indoor air quality procedure.”



BSR/ASHRAE Addendum c
to ANSI/ASHRAE Standard 62.1-2022

Public Review Draft

Proposed Addendum c to Standard 62.1-2022, Ventilation and Acceptable Indoor Air Quality

First Public Review (July 2023)
(Draft shows Proposed Changes to Current Standard)

1 Enter design information for Design Compounds, PM2.5

Design Compound	CAS Number	Third-Party Tested Efficiency	Outdoor Concentration (ug/m3)	Indoor Emission Rate
Acetaldehyde	75-70-0			Enter Emission Rate information in 'Generation Rates' tab for each occupancy category.
Acetone	67-64-1			
Benzene	71-43-2			
Dichloromethane	75-09-2			
Formaldehyde	50-00-0			
Naphthalene	91-20-3			
Phenol	108-95-2			
Tetrachloroethylene	127-18-4			
Toluene	108-88-3			
1,1,1-trichloroethane	71-55-6			
Xylene, total	108-83-3, 95-47-6, and 106-42-3			
Carbon monoxide	630-08-0			
PM2.5	-			
Ozone	10028-15-6			
Ammonia				

[Note: You can find EPA air quality data here](#)

2a Enter design information for project-specific design compounds

Design Compound	CAS Number	Outdoor Concentration	Design Limit	Exposure Period	Cognizant Authority	Indoor Emission Rate
						Enter Emission Rate information in 'Generation Rates' tab for each occupancy category.

2b Enter device cleaning efficiency for project-specific design compounds

Design Compound	CAS Number	Third-Party Tested Efficiency

► READ ME PROJECT IAQ INFO INPUT COMPLIANCE Single Zone, Location A1, IP Single Zone, Location A1, IP

IAQP for Reduced Ventilation

IMC Code

“Where a registered design professional demonstrates that an *engineered ventilation system design* will prevent the maximum concentration of contaminants from exceeding the obtainable by the rate of outdoor air ventilation determined in accordance with Section 403.3, the *minimum required rate of outdoor air shall be reduced* in accordance with such engineered system design.”

IMC Code Commentary

“An engineered ventilation system is more of a direct method of controlling air quality and would be classified as an “Indoor Air Quality Procedure” in ASHRAE 62.1.”

From IMC Section 403.2

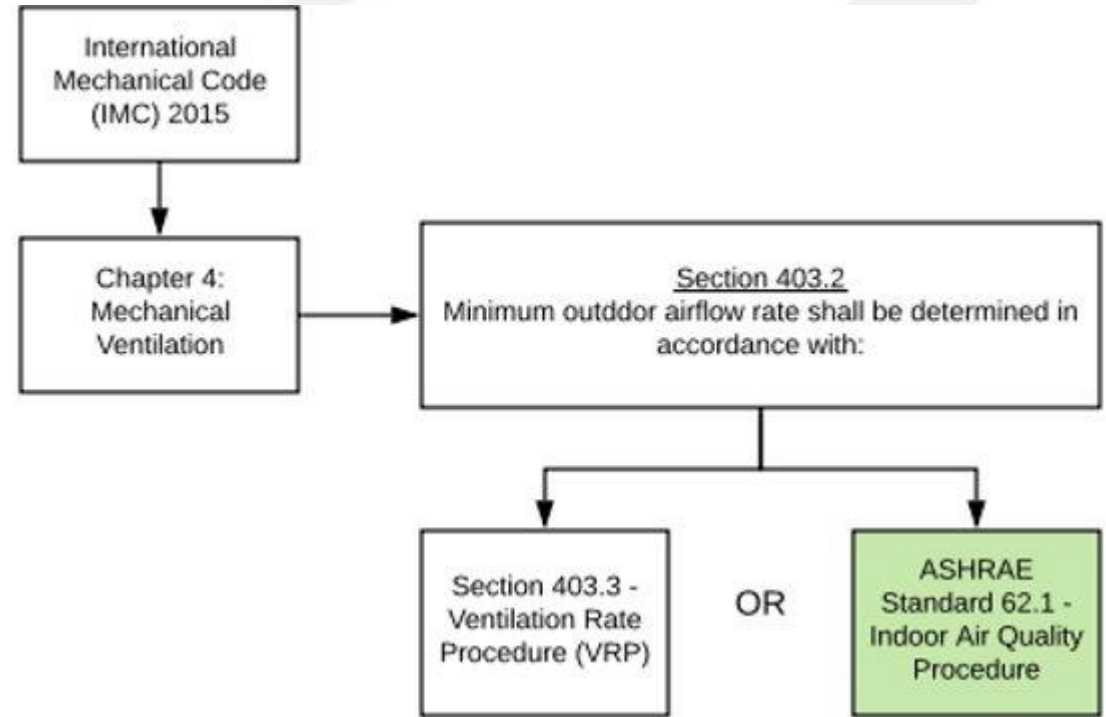

40-70% reduction vs. VRP

IAQP for Reduced Ventilation

Equipment Optimization & First Cost per ~20,000 ft²:

Capacity Savings	Equipment Savings
10-15 tons of Peak Cooling*	<ul style="list-style-type: none">•Reduce RTU and/or AHU capacity•Downsize chiller & cooling tower•Eliminate / reduce ERV•Downsize required capacity of renewables (solar/geothermal/etc.)•Eliminate DCV•Reduce OA and exhaust duct sizes
100k – 200K BTU of Peak Heating*	<ul style="list-style-type: none">•Downsize boiler or electric heat

Contaminant Reduction

Sorbent Media Blend



Sorbent media blend addresses all ASHRAE defined contaminants

Sorbent Filters

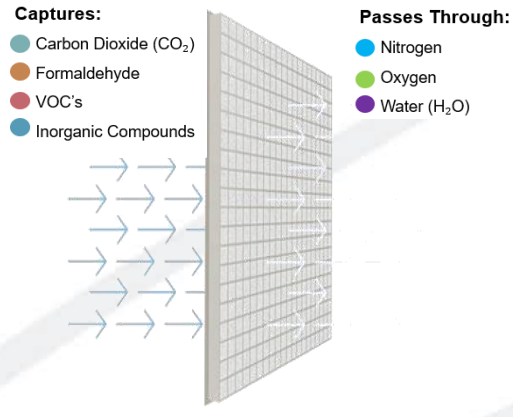

Media is loaded into sorbent filters used in air cleaning systems

Air Cleaning Systems

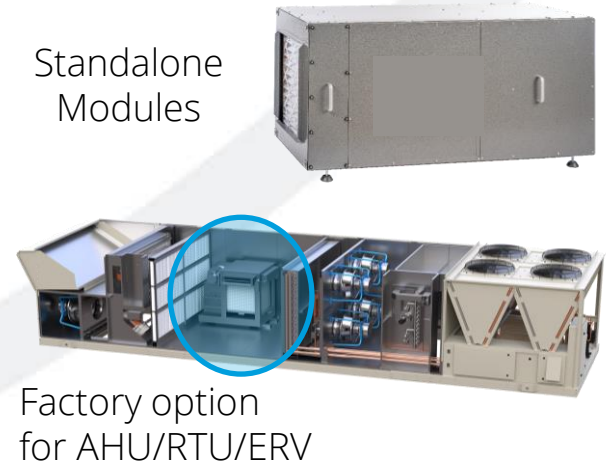

Filters are used in standalone units and inside traditional HVAC systems

Performance against all the ASHRAE defined contaminants has been demonstrated in third-party labs according to the ASHRAE 145.2 test method for gas-phase air cleaners and field validated by the U.S. Dept. of Energy.

Energy Reduction of Ventilation

The 40-40-40 Rule

Ventilation energy reduction is the lowest hanging fruit in building decarbonization

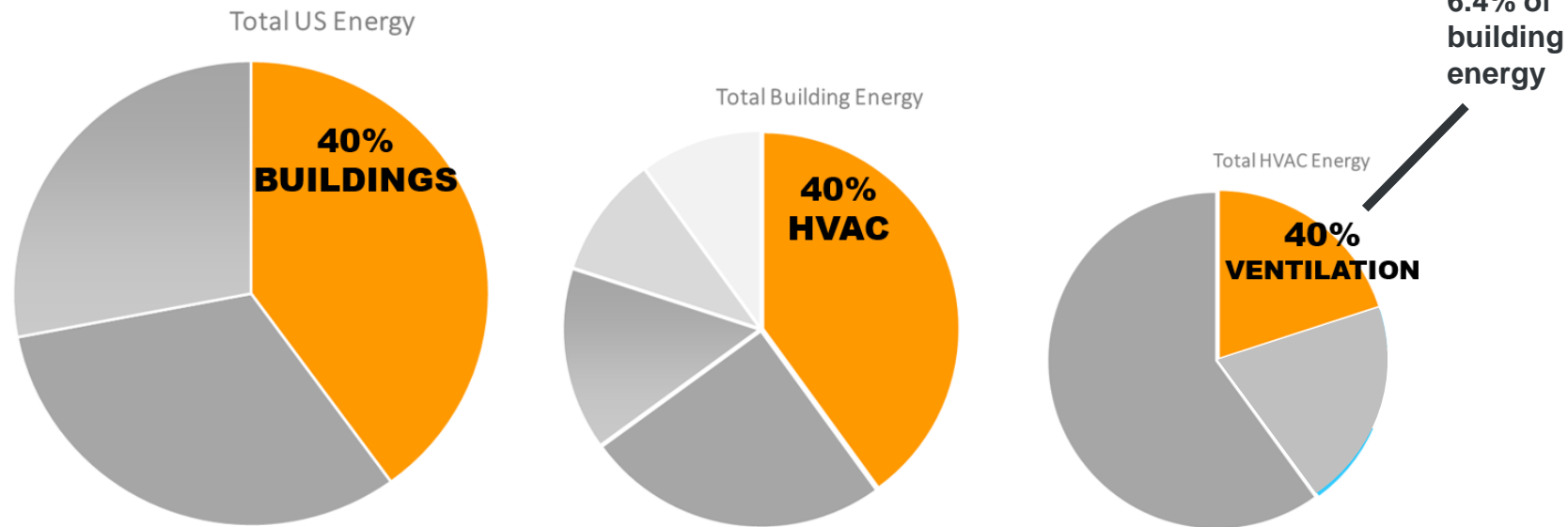

IAQP reduction potential is 40-75% of ventilation

This would reduce total building energy usage by 2.5% - 5%

What about ventilation air *energy recovery*?

What is the effectiveness/efficiency of the ventilation heat recovery?

50% was considered acceptable for many years

Massachusetts stretch code requires 70% ERR

Can we do better!?



Dual Core / Regen Core Heat Recovery

- **90%+ heating recovery**
- No defrost cycle required (we can right-size heating!)
- Often removes need for *any* aux heat
- Can be used with packaged ASHP's up to 120 tons

In			
Nominal volume [cfm]	8000	8000	
Mass flow [lb/min]	599	599	
Density [lb/ft ³]	0.0862	0.0747	
Dry-bulb temp. [°F]	0.0	70.0	
Wet-bulb temp. [°F]	0.0	53.0	
Absolute humidity [gr/lb]	5.5	32.6	
Enthalpy [BTU/lb]	0.84	21.96	
Out			
Eff. volume flow [cfm]	7936	7038	
Density [lb/ft ³]	0.0755	0.0852	
Dry-bulb temp. [°F]	64.2	5.8	
Wet-bulb temp. [°F]	49.1	5.7	
Absolute humidity [gr/lb]	27.6	7.3	
Enthalpy [BTU/lb]	19.76	2.50	

0F air in

64F air out
(~67F after fan heat)

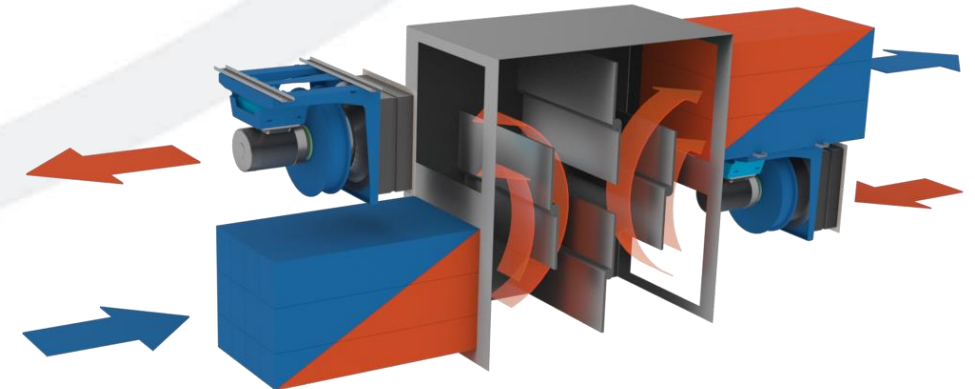
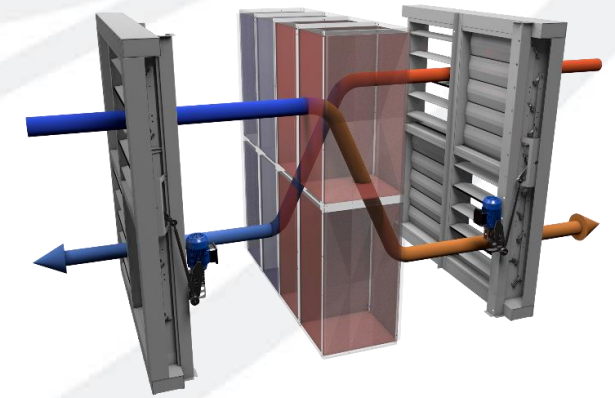

Energy Reduction of Ventilation

The 40-40-40 Rule

Ventilation energy reduction is the lowest hanging fruit in building decarbonization

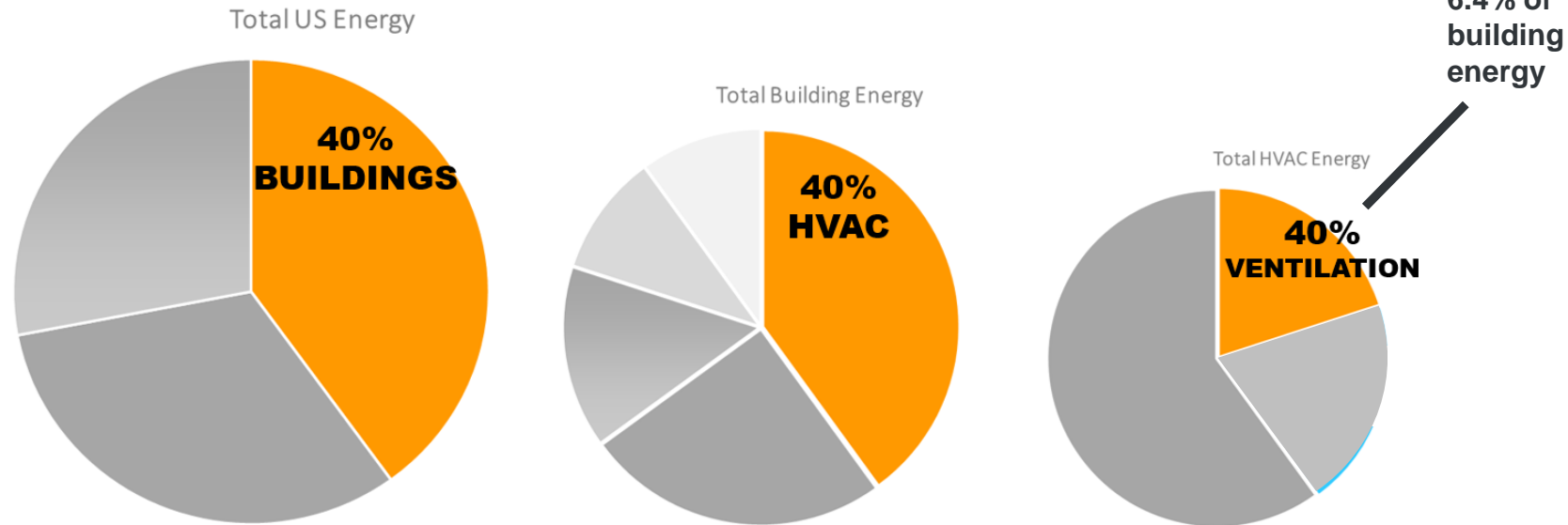

IAQP reduction potential is 40-75% of ventilation + 90% heat recovery

This would reduce total building energy usage by 2.5% - 5%
3-5.5%

Reducing Demand From Central Heating Systems

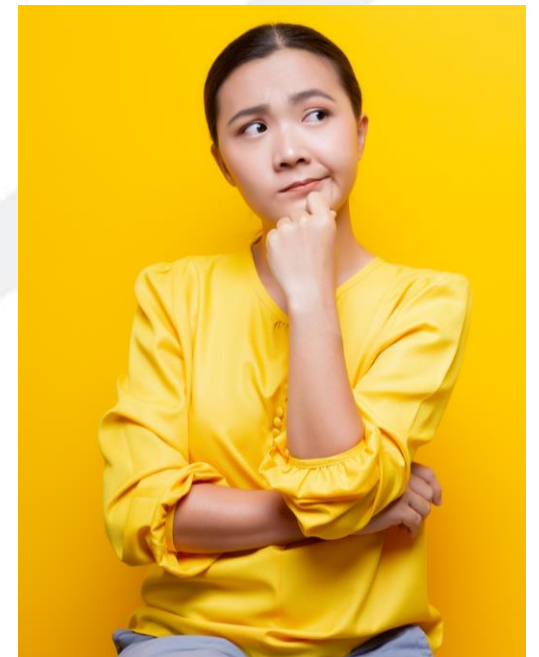
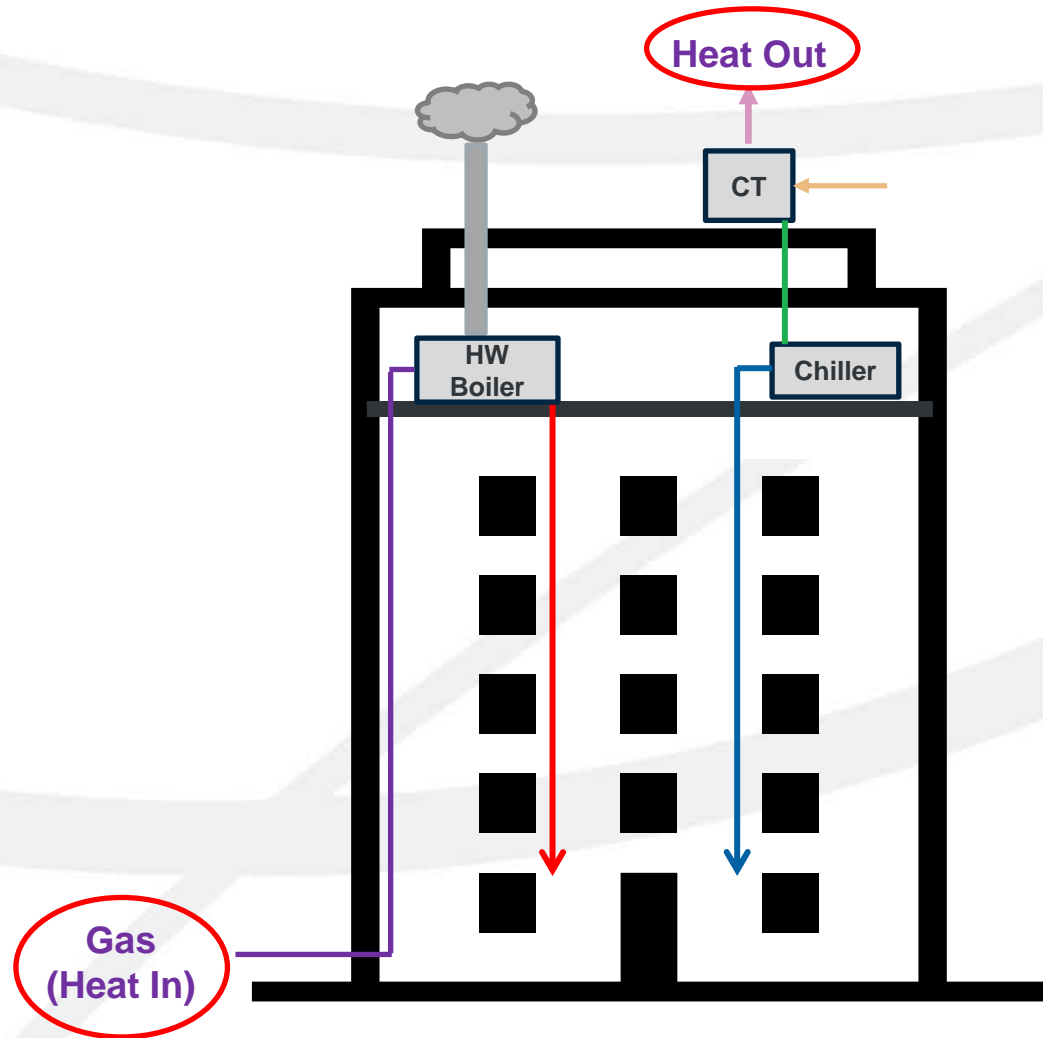

Reducing Demand From Central Heating Systems

SIMULTANEOUS HEATING AND COOLING

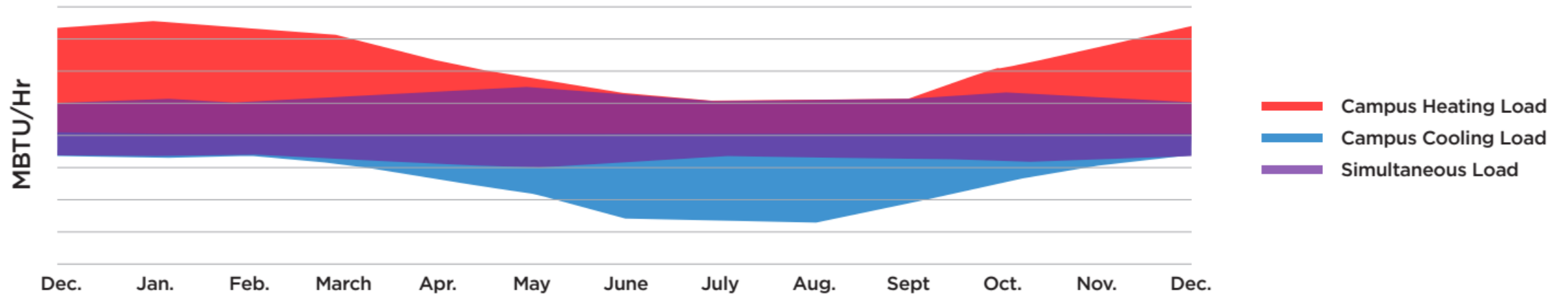

Reducing Demand From Central Heating Systems

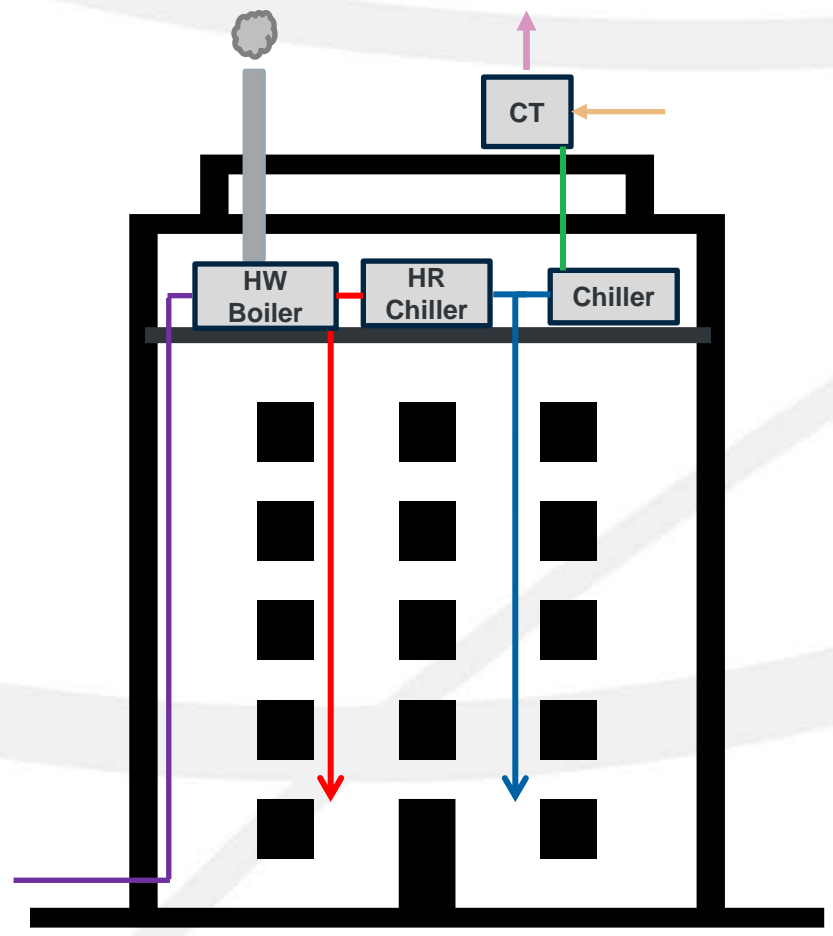

Open Loops are still everywhere - CLOSE THEM!

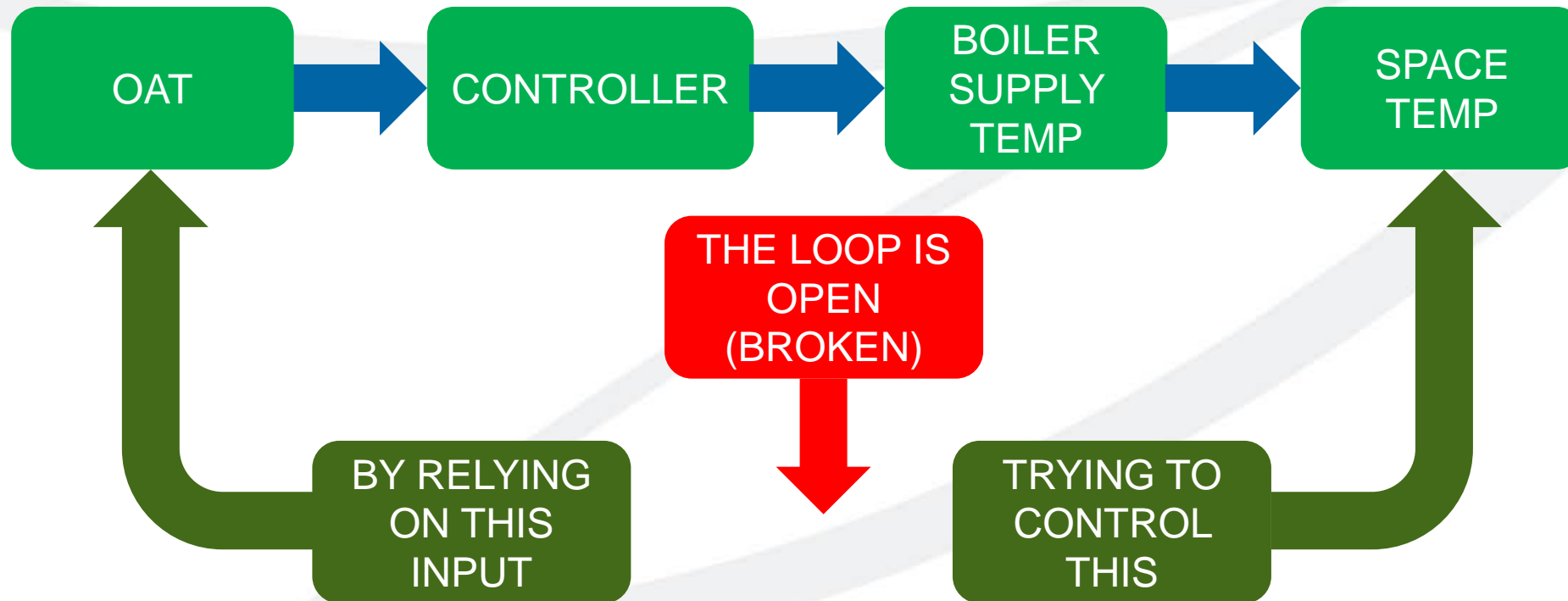

Automation 101

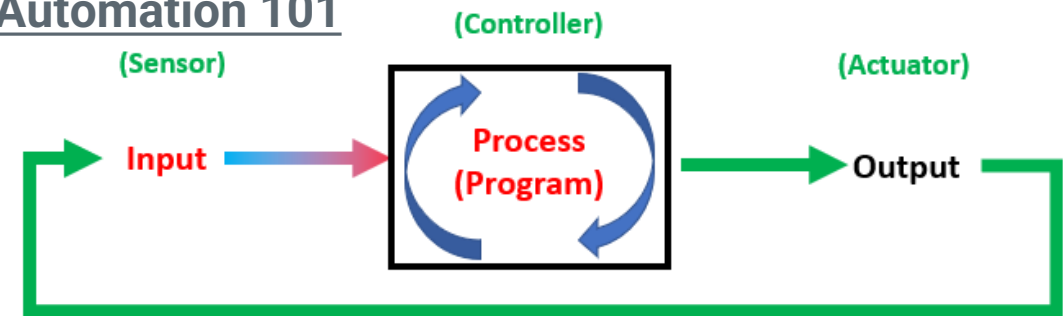

Closing Heating and Cooling Control Loops

The setpoint of a PID using VAV Discharge air temperature as its input and whose output controls the terminal heat.

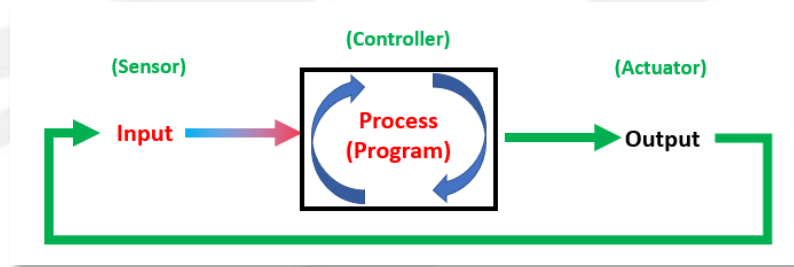
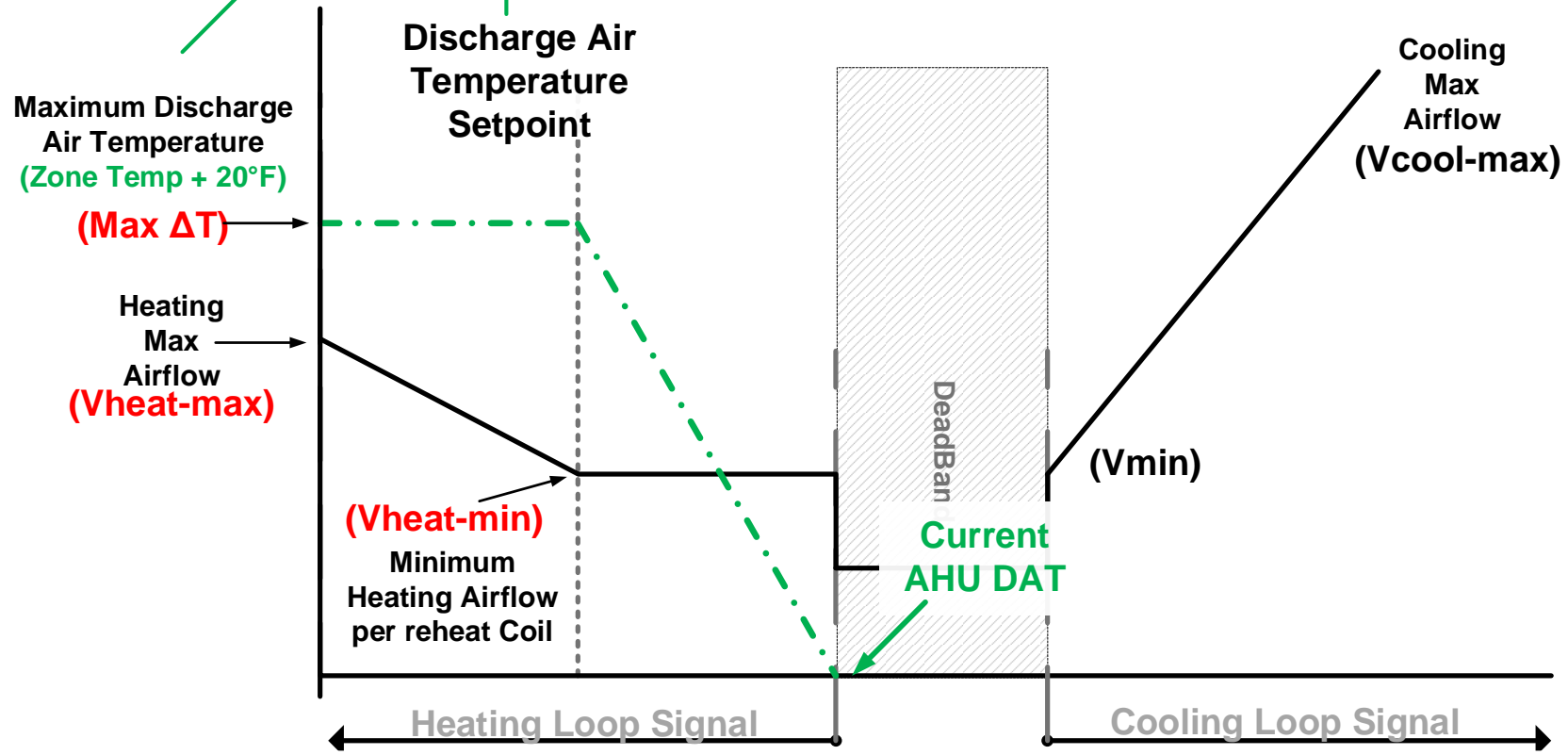

Input:

- Space Temp

Process

- Heating PID
- Cooling PID

Output

- Reset Airflow First (Lower Fan kW)
- Reset Valve Position Second (Lower BTU)

Water-Source Domestic Water Heaters

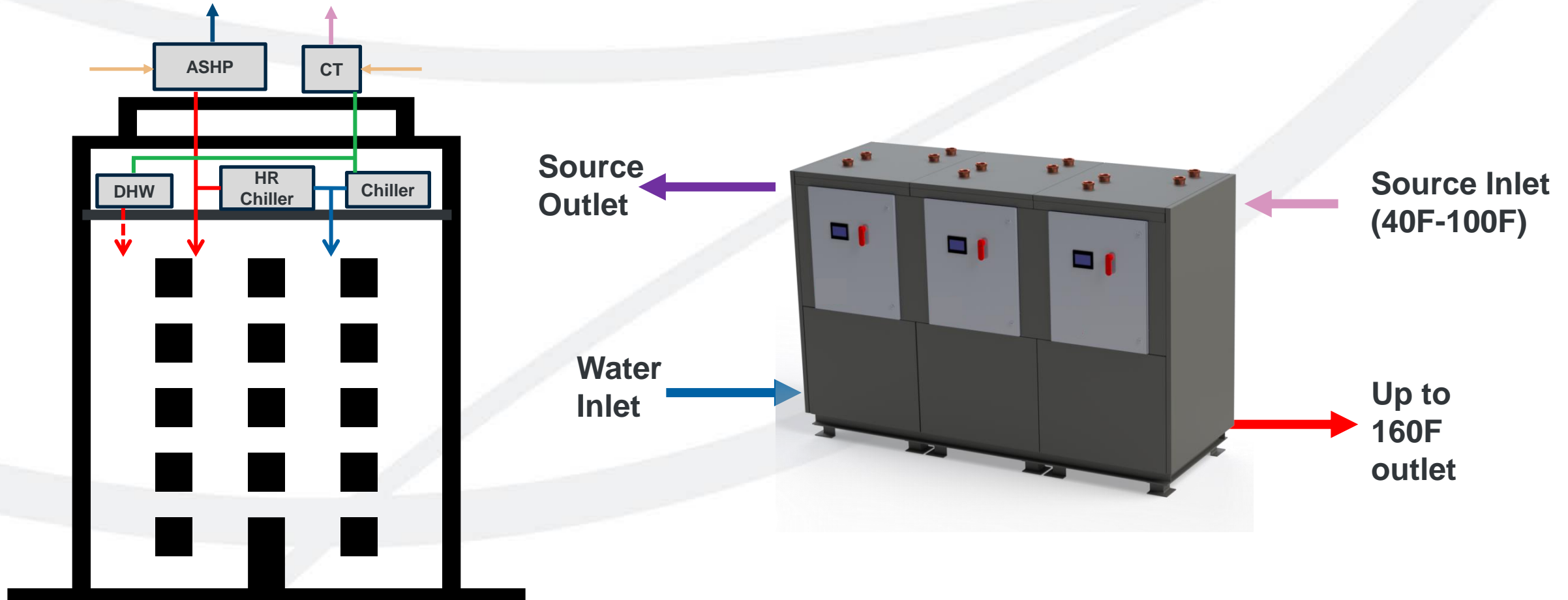

Air-Source Domestic Water Heaters

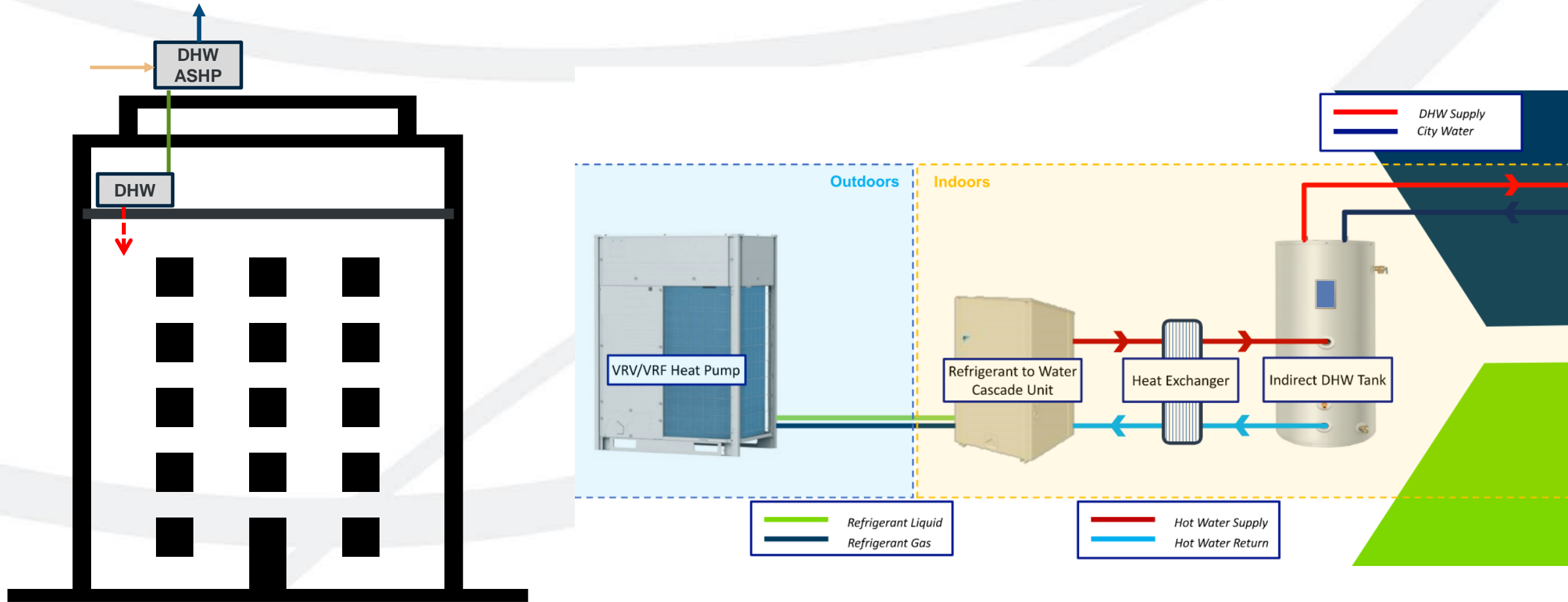

Where else can we recover heat?

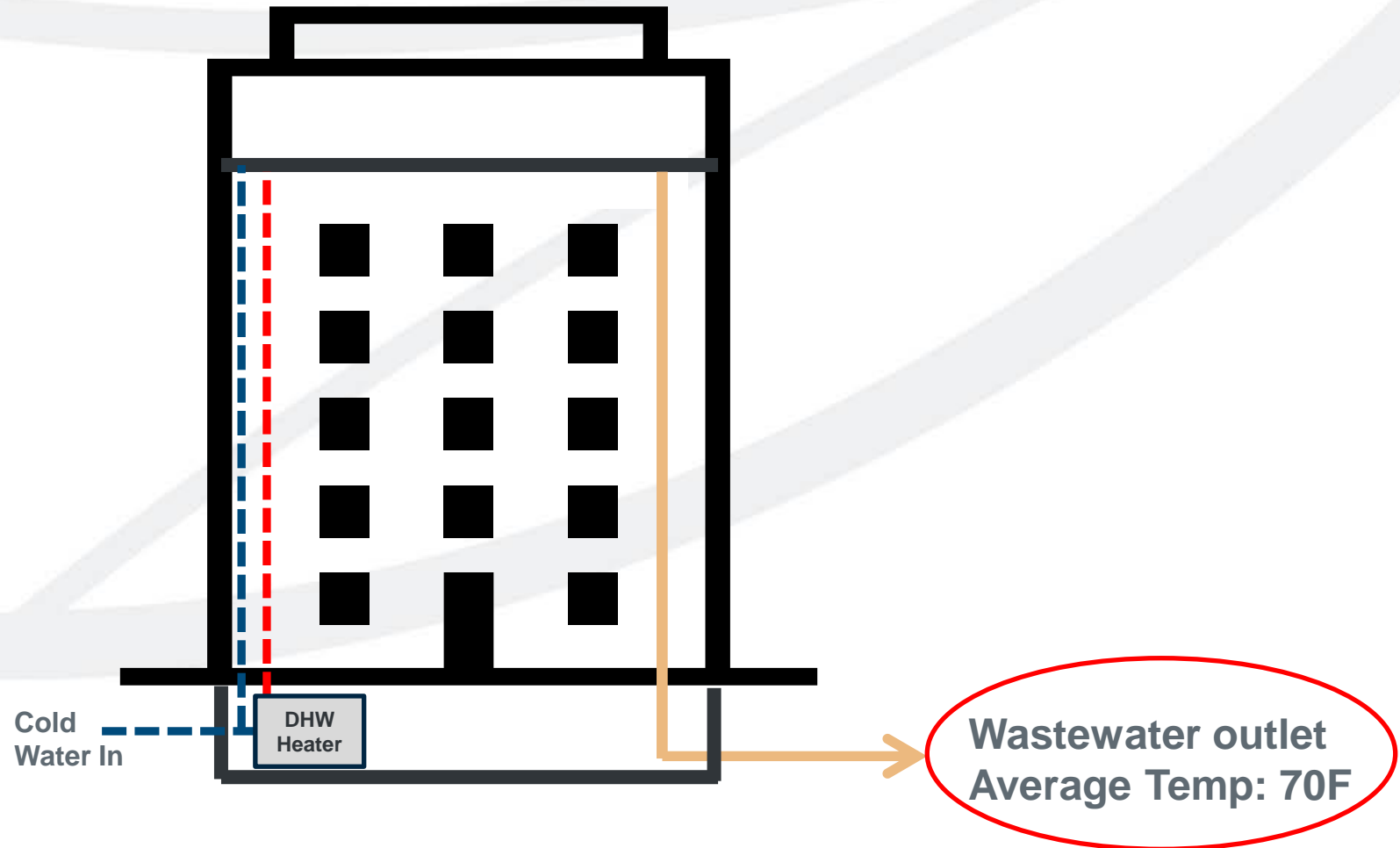



The Average Person Uses **24 Gallons** of **Hot Water** per Day at 140°F*

- Average Residential Wastewater Temperature is 70°F
- Commercial & Industrial Wastewater Temperature can reach 140°F or Higher

Wastewater sources:

- Black and Grey Water Within Buildings
- Sanitary Sewers
- Lift Stations/Treatment Centres

**estimated 60 gallons/day of wastewater*



Where else can we recover heat?

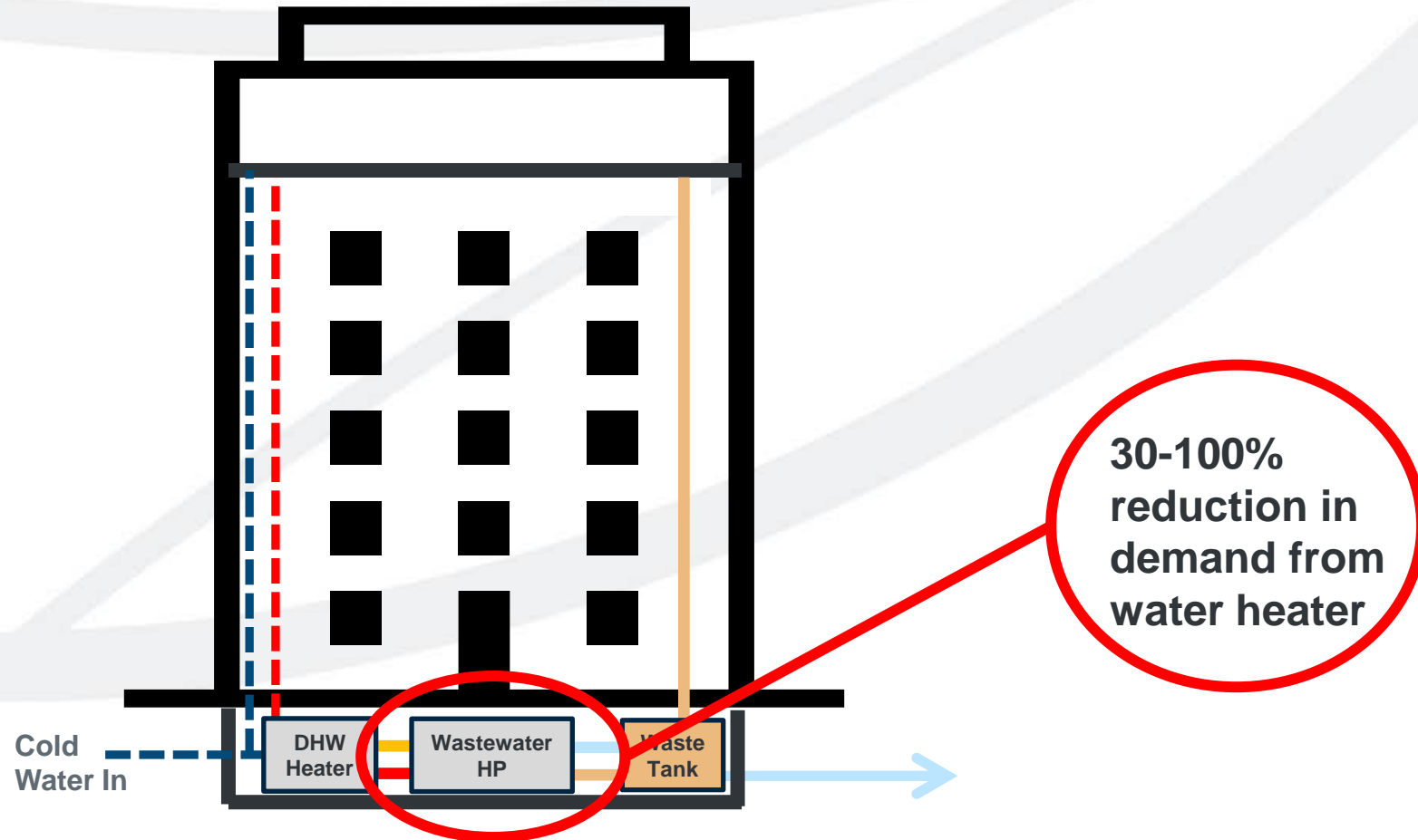

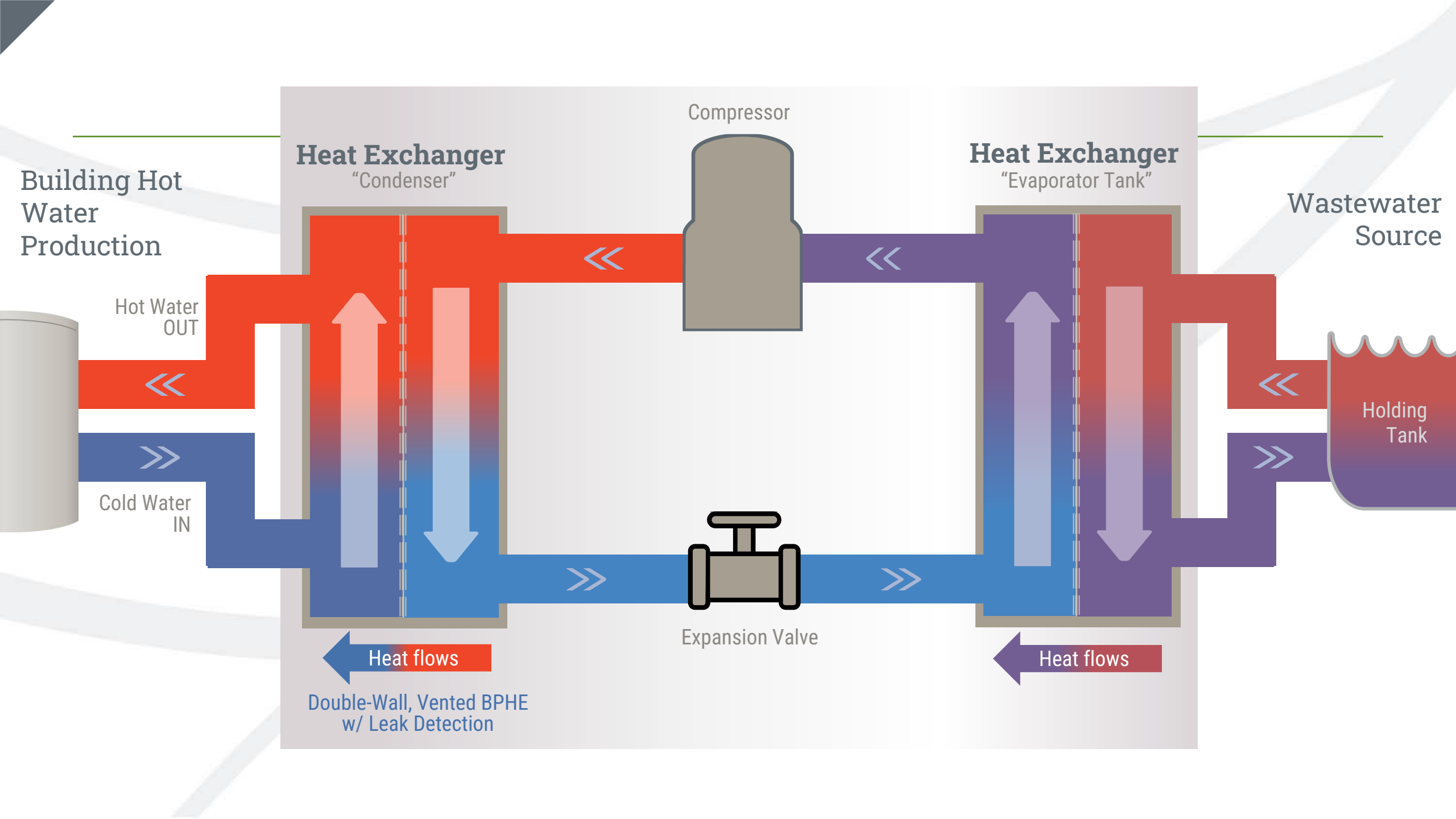

Typical Above-Grade Installation

Energy Recovery
(Heating)

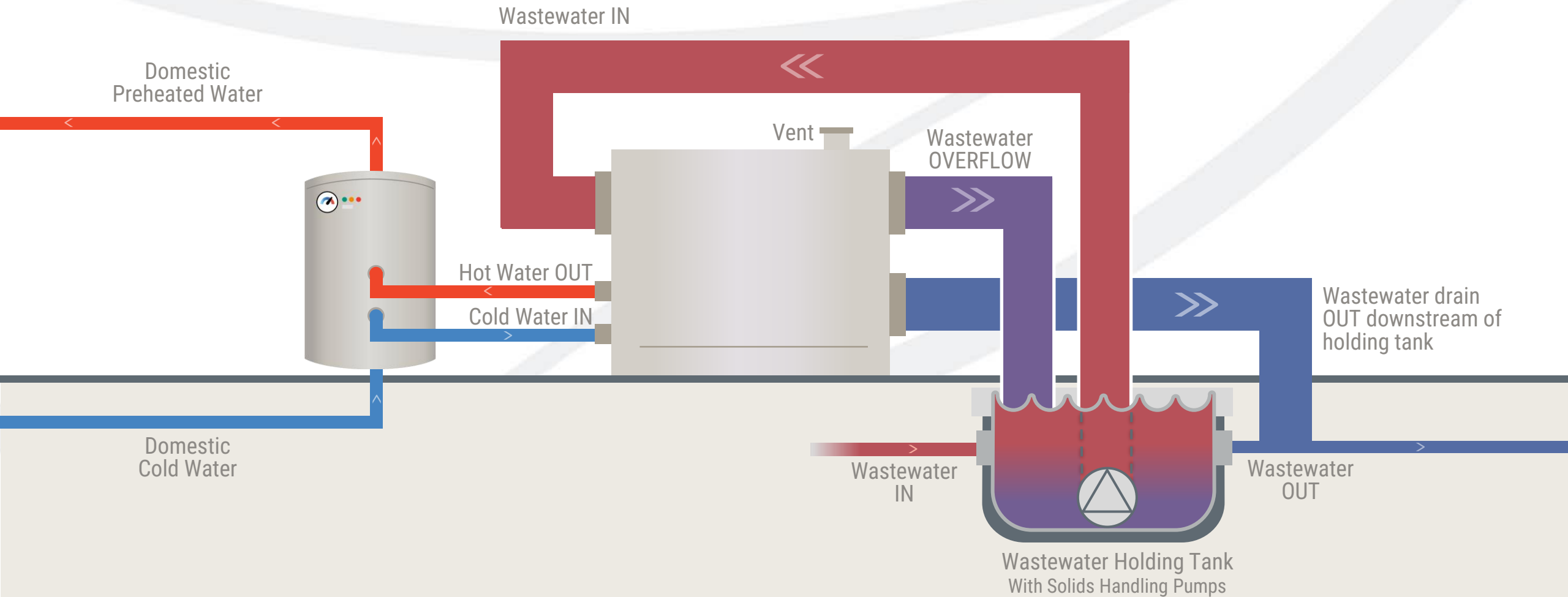

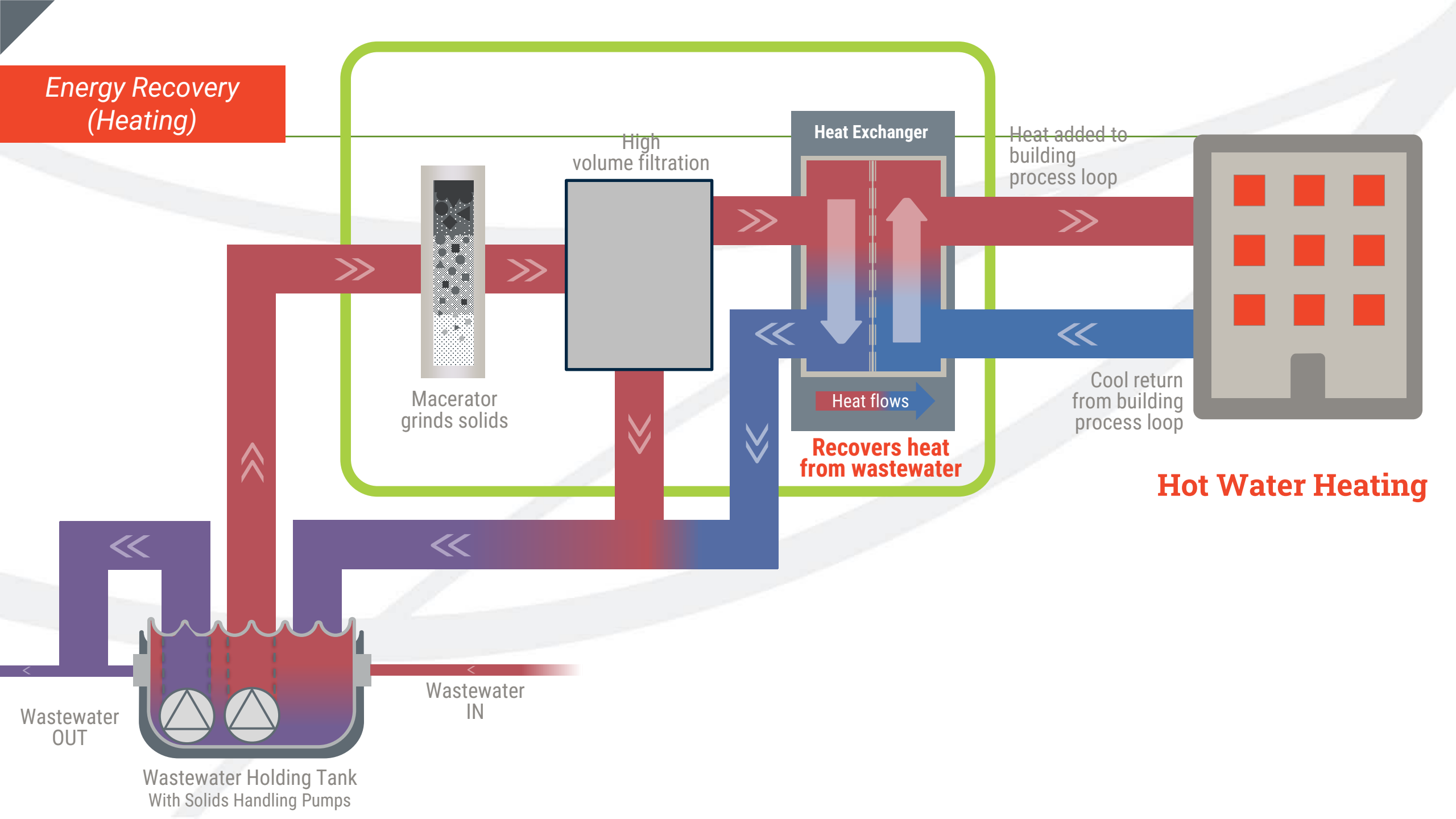

Energy Recovery (Heating)

High volume filtration

Heat Exchanger

Heat added to building process loop

Macerator grinds solids

Recover heat from wastewater

Cool return from building process loop

Hot Water Heating

Wastewater OUT

Wastewater IN

Wastewater Holding Tank With Solids Handling Pumps

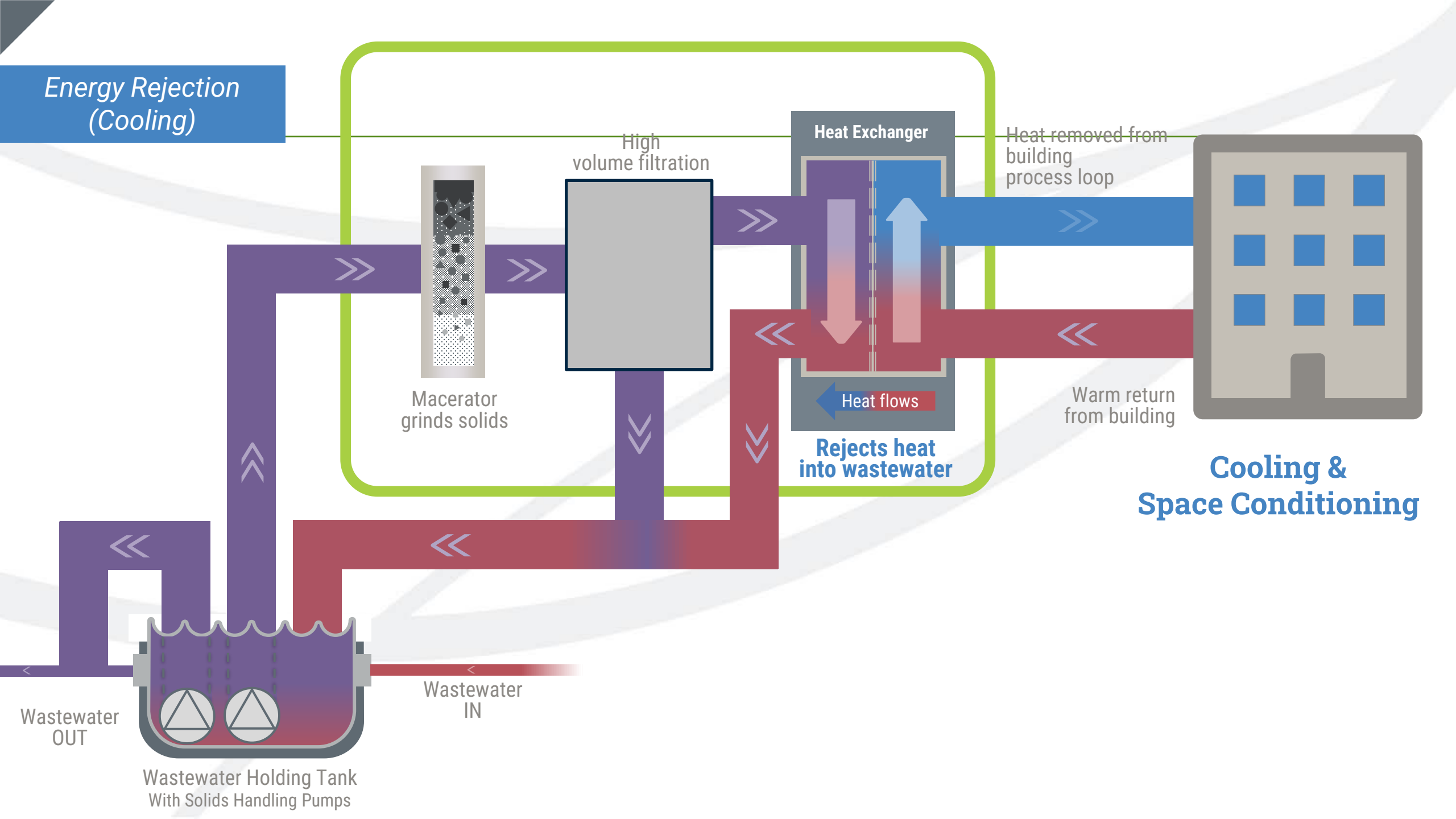

Energy Rejection
(Cooling)

High
volume filtration

Heat Exchanger

Heat removed from
building
process loop

Macerator
grinds solids

Warm return
from building

Rejects heat
into wastewater

Cooling &
Space Conditioning

Wastewater
OUT

Wastewater
IN

Wastewater Holding Tank
With Solids Handling Pumps

Reducing Heating Loads – With Controls

Do we have any low hanging fruit with controls/programming?

ASHRAE Guideline 36 : High-Performance BAS

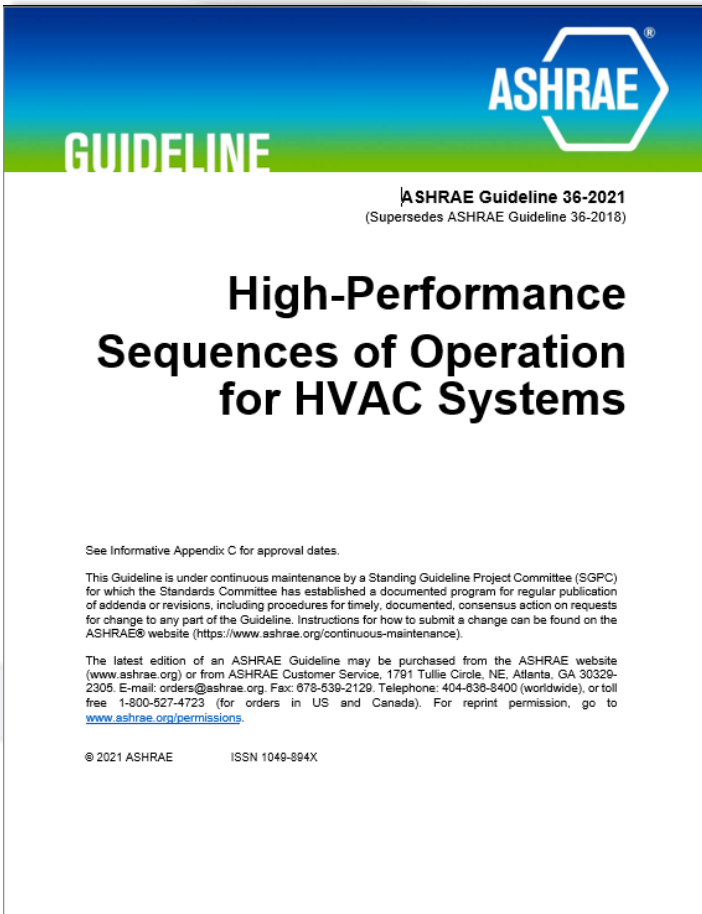

ASHRAE
GUIDELINE

ASHRAE Guideline 36-2021
(Supersedes ASHRAE Guideline 36-2018)

High-Performance Sequences of Operation for HVAC Systems

See Informative Appendix C for approval dates.

This Guideline is under continuous maintenance by a Standing Guideline Project Committee (SGPC) for which the Standards Committee has established a documented program for regular publication of addenda or revisions, including procedures for timely, documented, consensus action on requests for change to any part of the Guideline. Instructions for how to submit a change can be found on the ASHRAE® website (<https://www.ashrae.org/continuous-maintenance>).

The latest edition of an ASHRAE Guideline may be purchased from the ASHRAE website (www.ashrae.org) or from ASHRAE Customer Service, 1791 Tullie Circle, NE, Atlanta, GA 30329-2305. E-mail: orders@ashrae.org; Fax: 678-539-2129; Telephone: 404-638-8400 (worldwide), or toll free 1-800-627-4723 (for orders in US and Canada). For reprint permission, go to www.ashrae.org/permissions.

© 2021 ASHRAE ISSN 1049-894X

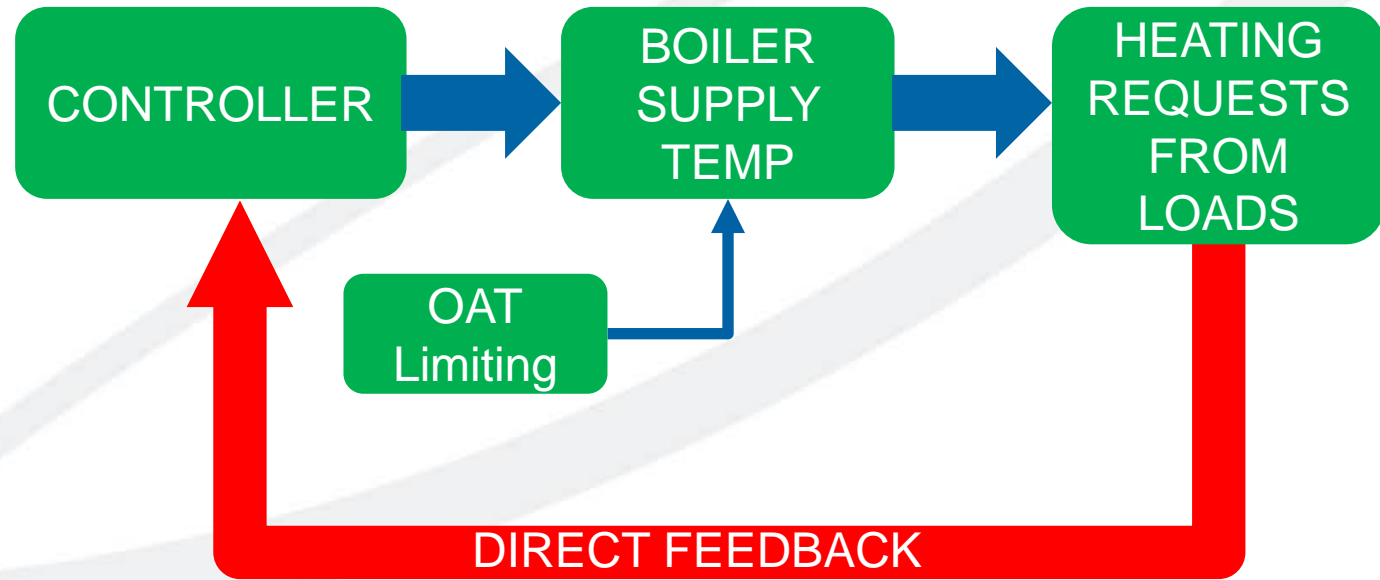

Reduce Ventilation and Relax CO2 Setpoints

What are the symptoms of different levels of exposure?

5,000 ppm (0.5%) OSHA Permissible Exposure Limit (PEL) and ACGIH Threshold Limit Value (TLV) for 8-hour exposure

ESHG-Health-02.00

FSIS Environmental, Safety and Health Group

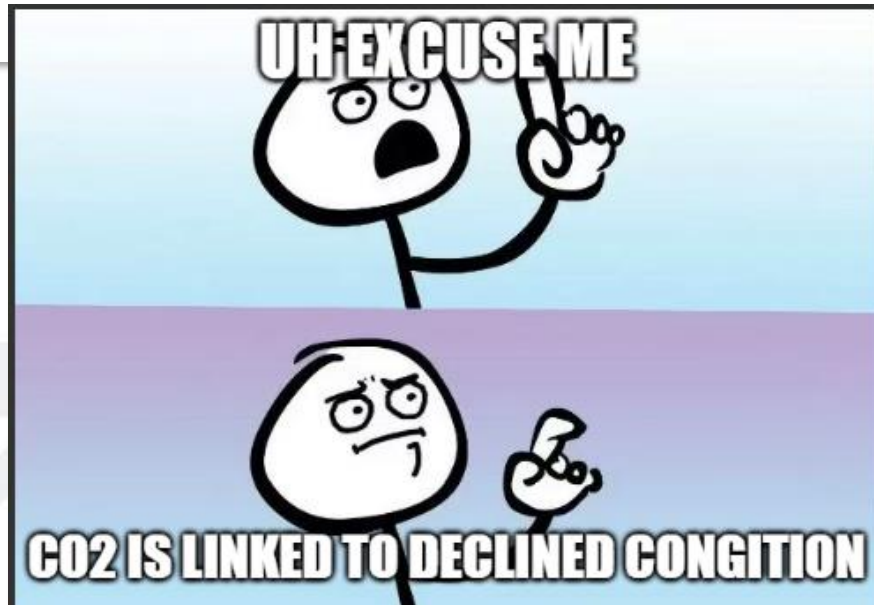

Relax CO₂ Setpoints and implement DCV



NASA-STD-3001 Technical Brief
OCHMO-TB-004

Carbon Dioxide (CO₂)

Background

Effects of CO₂ on Cognitive Functioning

Prior research offers conflicting data on CO₂ exposure and the effects on cognitive functioning, including memory, concentration, decision-making, and task performance. However, several recent terrestrial studies have shown the CO₂ exposure at levels currently maintained onboard spacecraft and submarines does not reduce cognition and performance in astronaut-like subjects or submarine officers.

- *Effects of acute exposures to carbon dioxide on decision-making and cognition in astronaut-like subjects* (Scully et al., 2019). Findings state "There were no clear dose-response patterns for performance on either Strategic Management Simulation or Cognition".
- *Acute Exposure to Low-to-Moderate Carbon Dioxide Levels and Submariner Decision Making* (Rodehe et al., 2018). Findings state "There were no significant differences for any of the nine Strategic Management Simulation measures of decision making between CO₂ exposure conditions".
- *Effects of -12° head-down tilt with and without elevated levels of CO₂ on cognitive performance: the SPACECOT study* (Basner et al., 2017). Findings state "There were no statistically significant time-in-CO₂ effects for any cognitive outcome".



Agenda

- Part 1 – Introduction / Background
- Part 2 – Reducing Heating Loads
- **Part 3 – Electrifying Heating Systems**
- Part 4 – Reducing Fan Energy
- Part 5 – The Importance of Intelligent Building Controls

Where are we consuming fossil fuels?

- Building Heating
- Domestic Hot Water
- Humidification

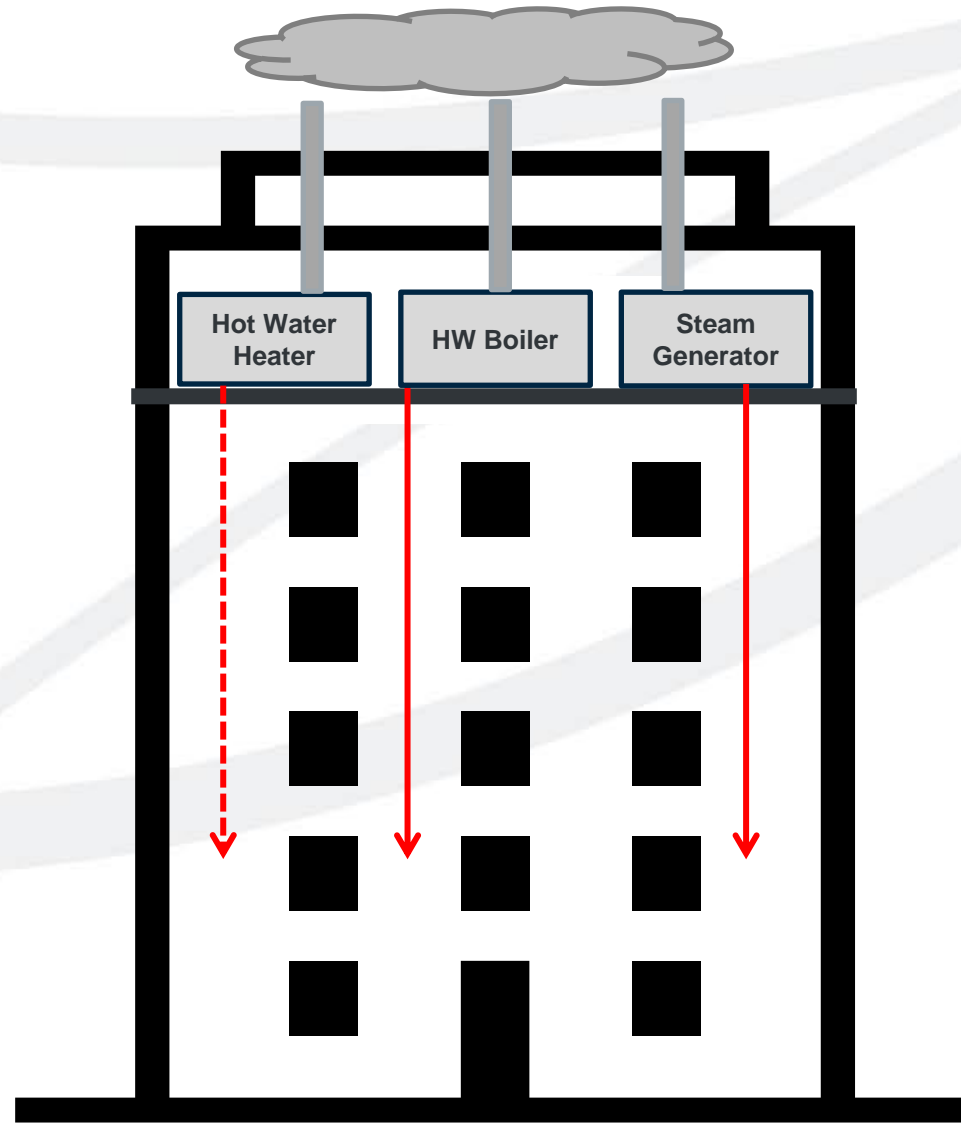

Where are we consuming fossil fuels?

- Building Heating

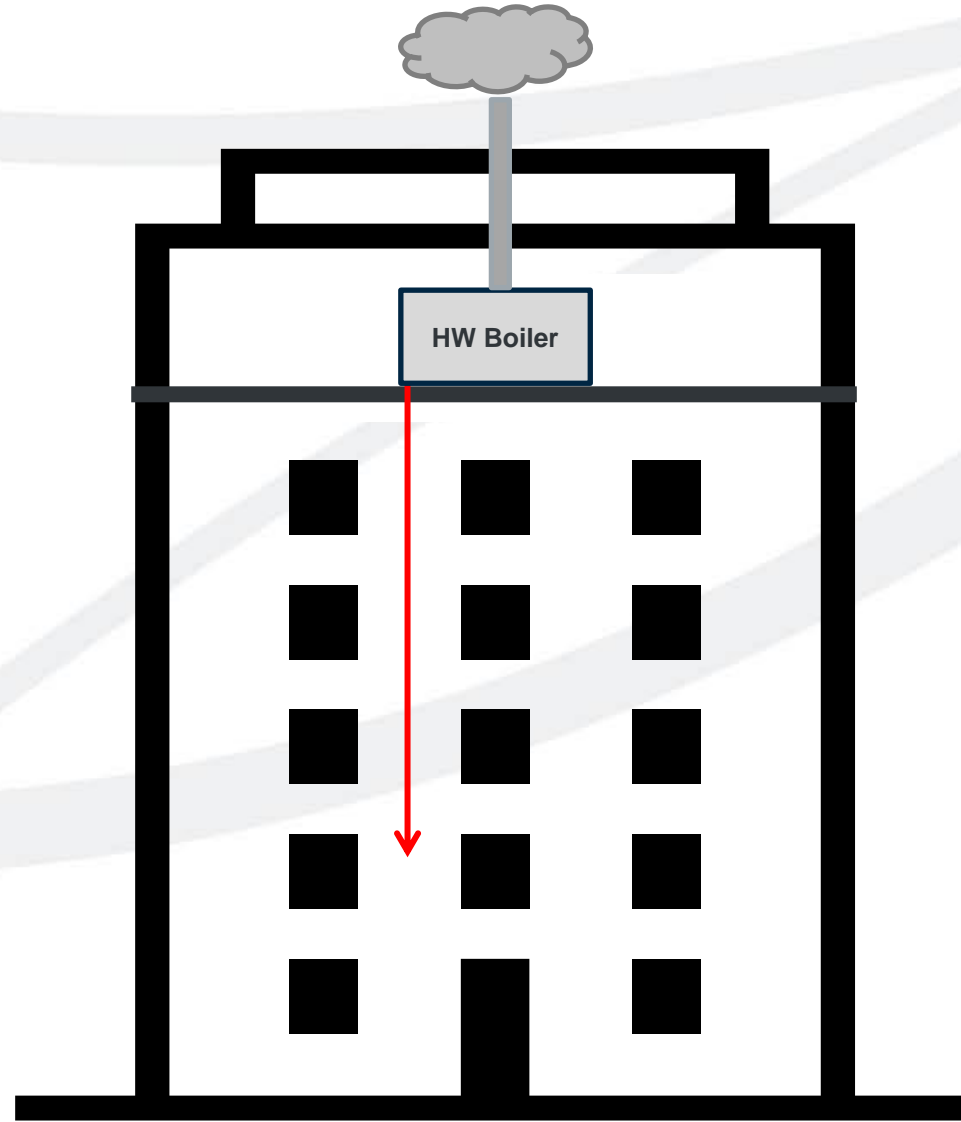

Where are we consuming fossil fuels?

- Building Heating

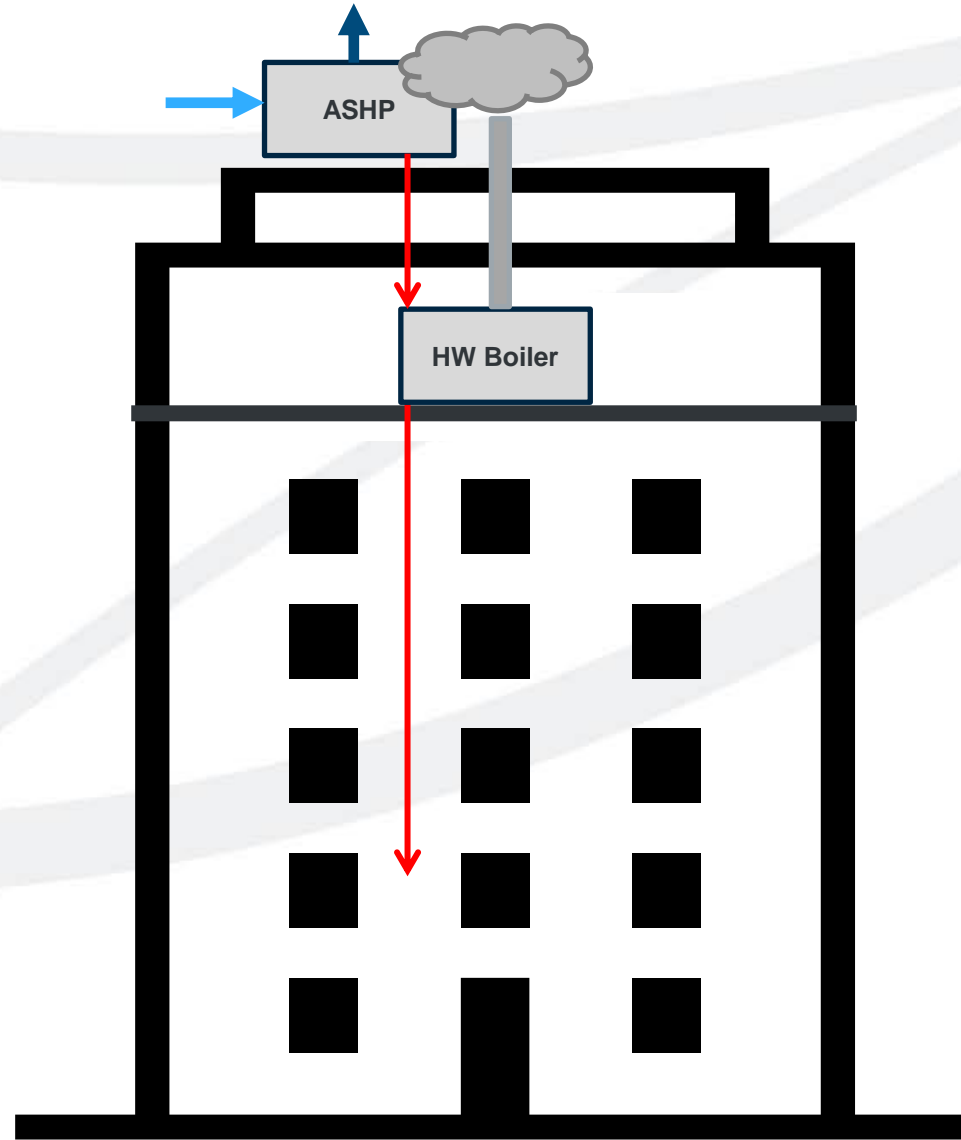

Building Heating – Air-to-Water Heat Pumps

- **Temperatures**
 - **Generally limited to 130F greater than ambient temp**
 - **Many existing buildings with 160-180F HW temps**
- **Physical space**
 - **Tall buildings = limited roof space**
- **Cost**
 - **Equipment + install + structural modifications**

Building Heating – Air-to-Water Heat Pumps

How do I get 180F HW with an ASHP?

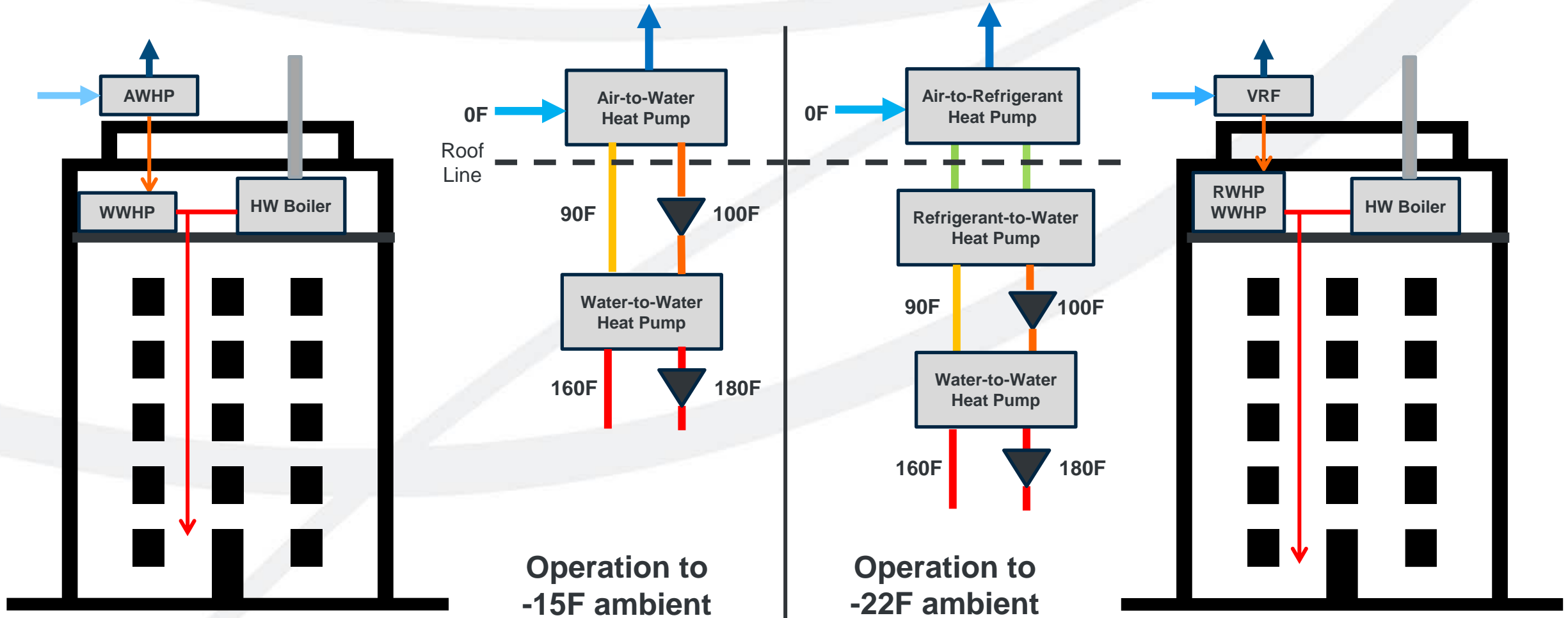

Building Heating – Air-to-Water Heat Pumps

Does it make sense to make 180F HW with an ASHP?

There are caveats. We can't cheat physics.

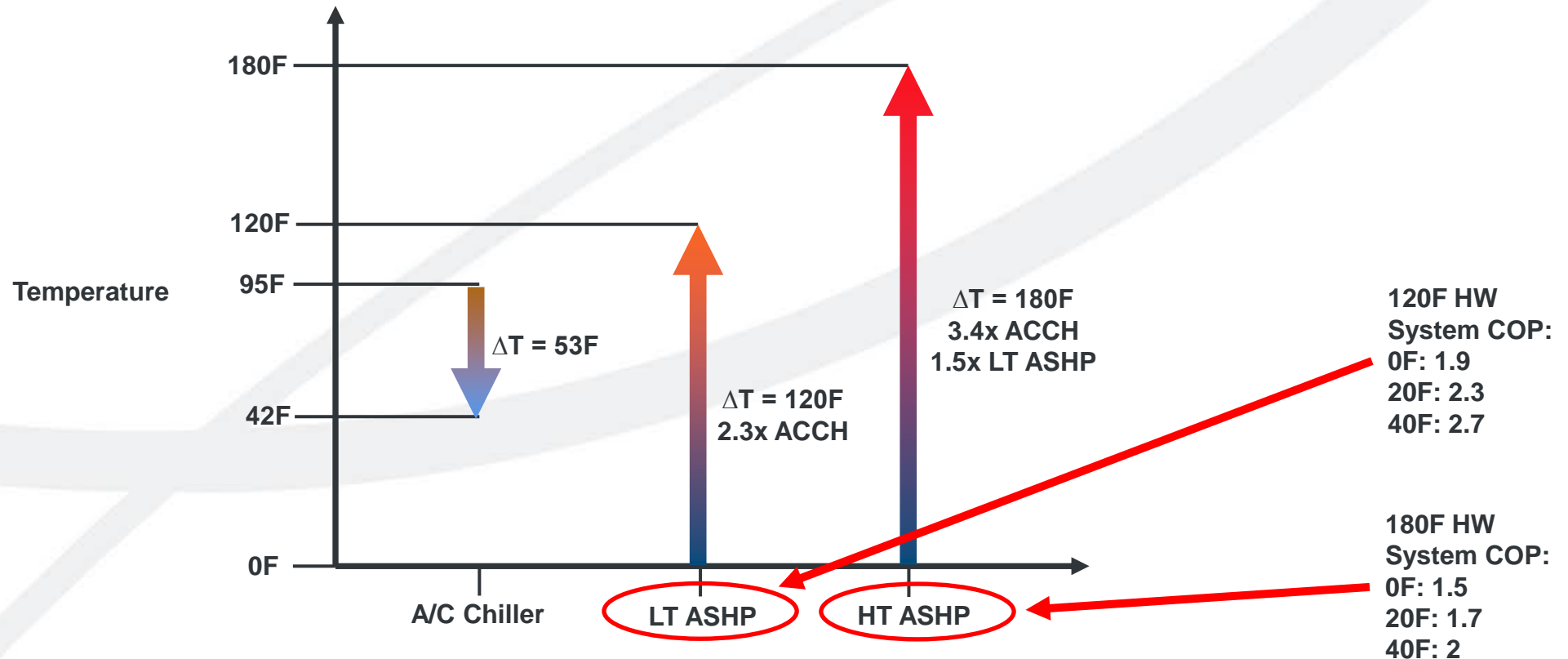

Building Heating – Air-to-Water Heat Pumps

What if we cover *part* of the load with ASHP's?

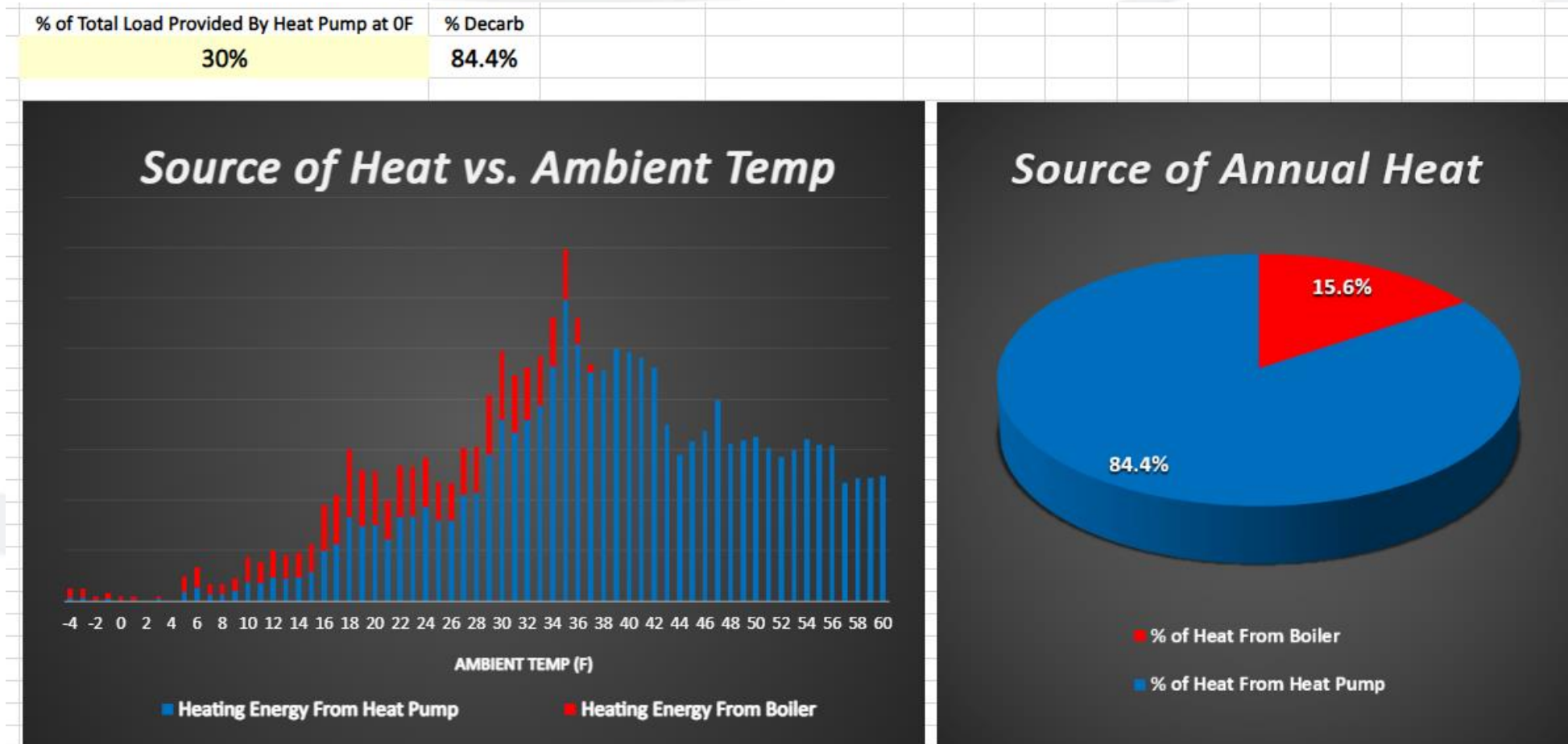

Building Heating – Air-to-Water Heat Pumps

What if we cover *part* of the load with ASHP's?

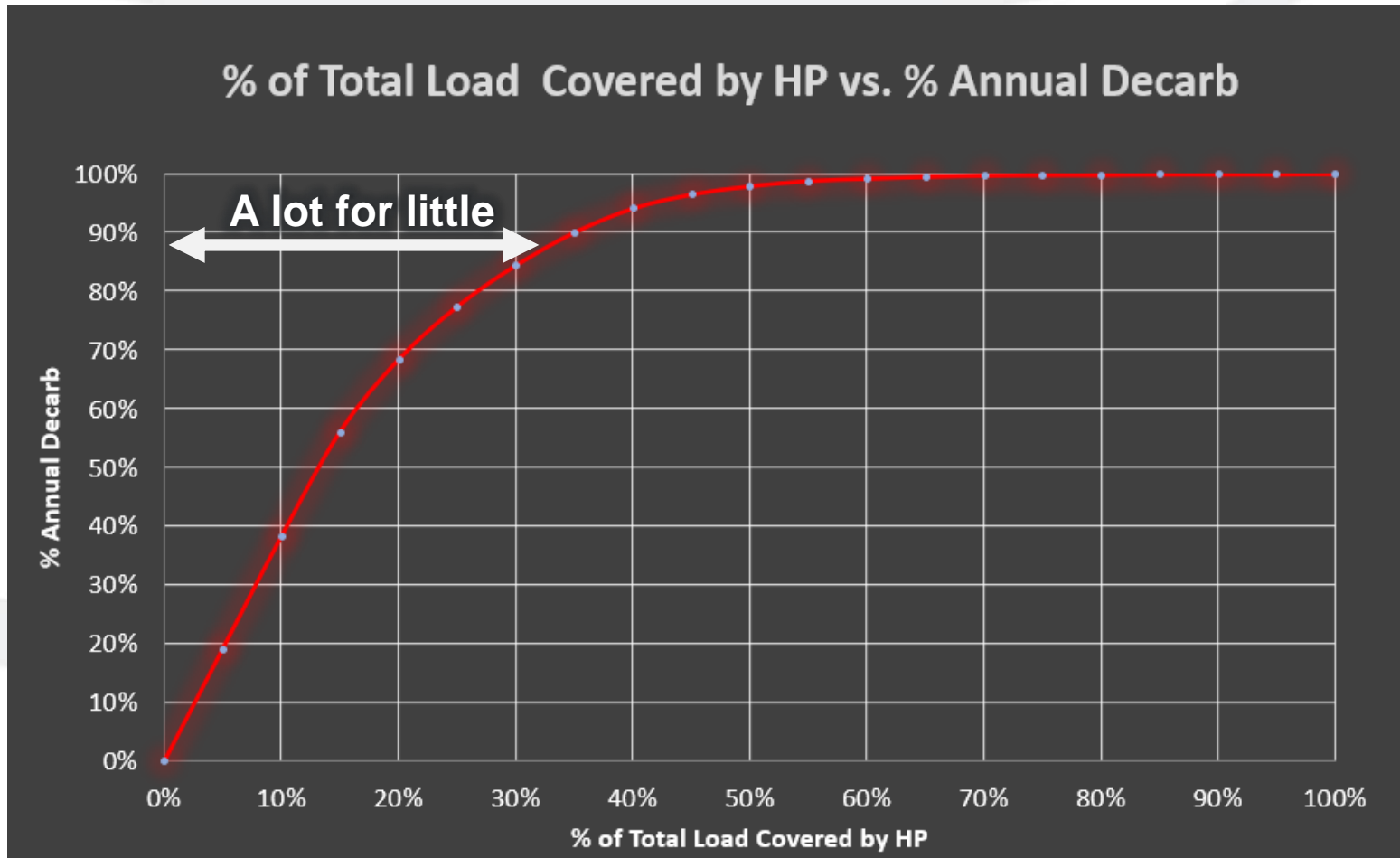

Capital Equipment vs. Value

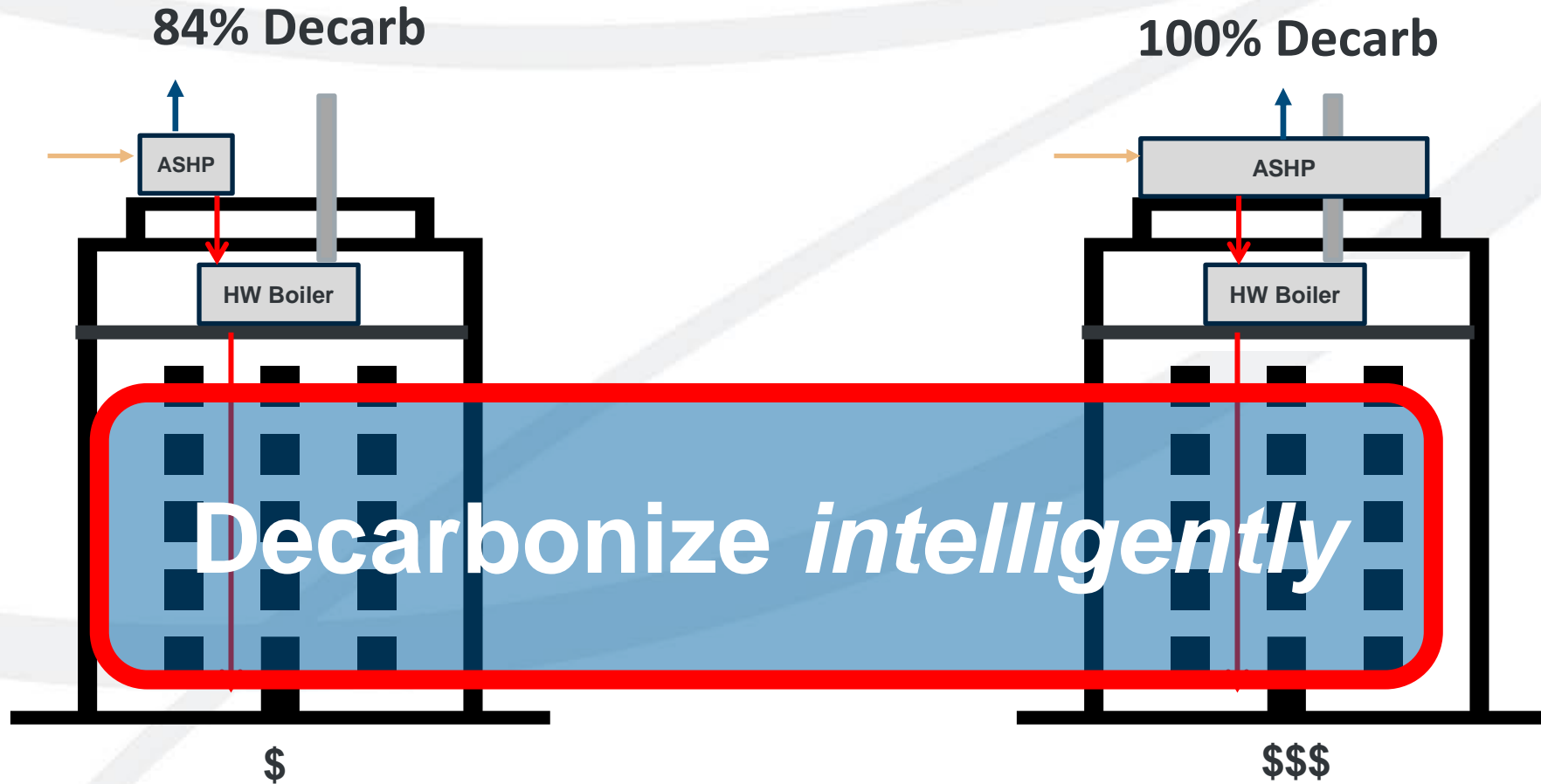

Air-Cooled Chiller Upgrades/Conversions

Air-Cooled Chiller

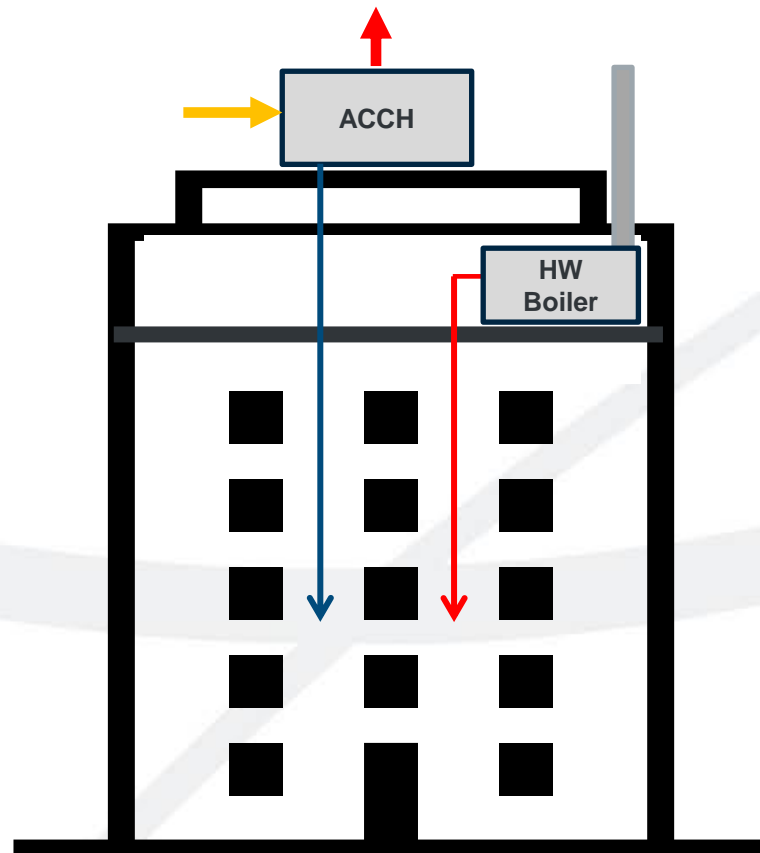

Air-Cooled Heat Pump
(Heat Recovery Available)

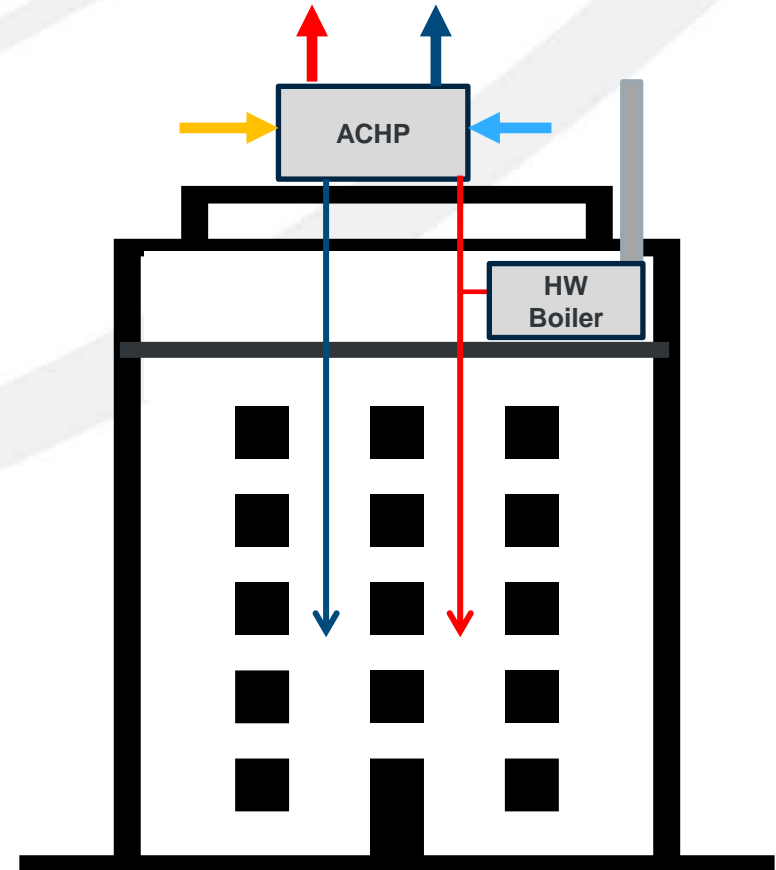

Air-to-Water Heat Pumps with Heat Recovery

- Now available with inverter compressor technology to achieve new high levels of efficiency
- Operation to -15F ambient
- Fluid temps up to ~130F above ambient
- Available with R-454B



44°F Cooling



120°F Heating

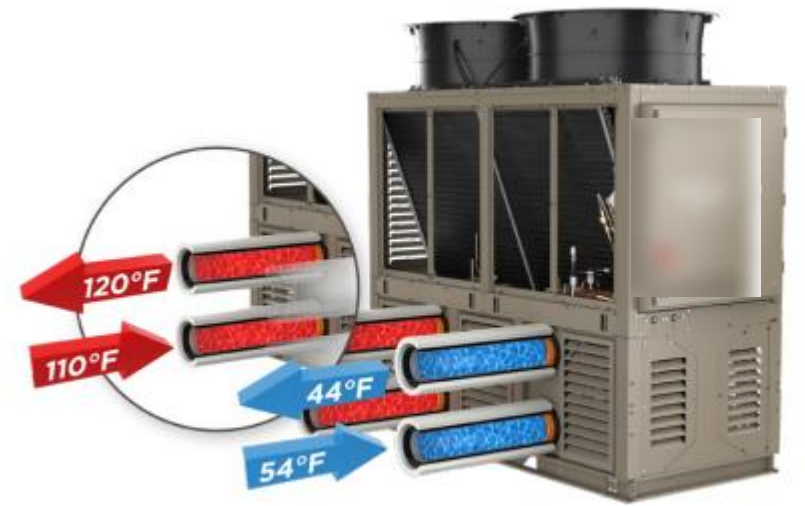

Simultaneous Heating & Cooling

Water-Source Heat Pump – Boiler Heating

WSHP + Cooling Tower + Boiler

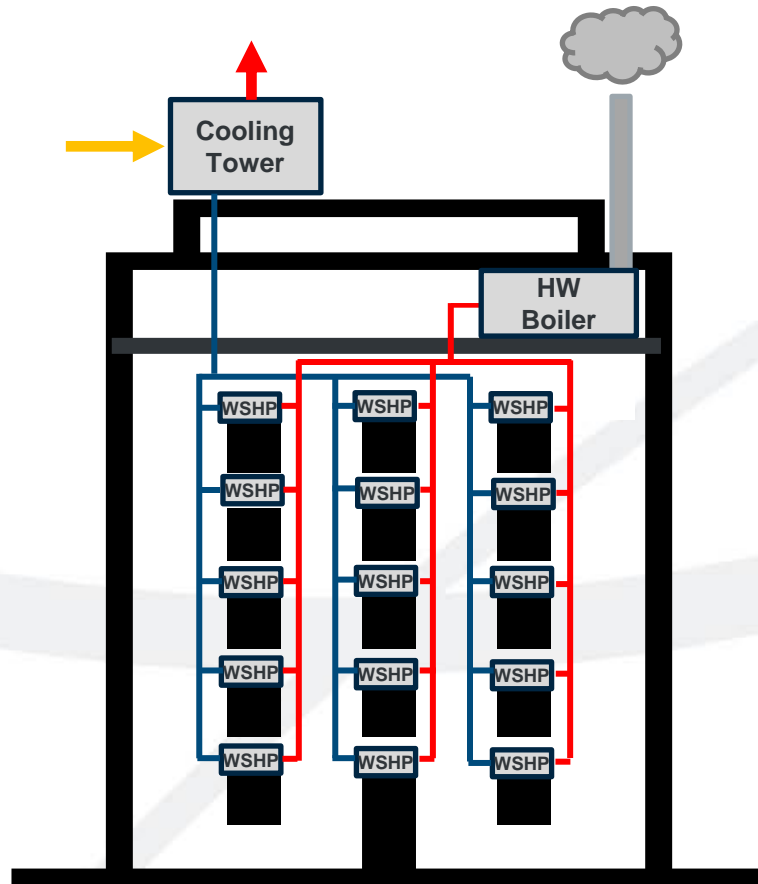

WSHP + Cooling Tower + Boiler
+ Air-Source Heat Pump

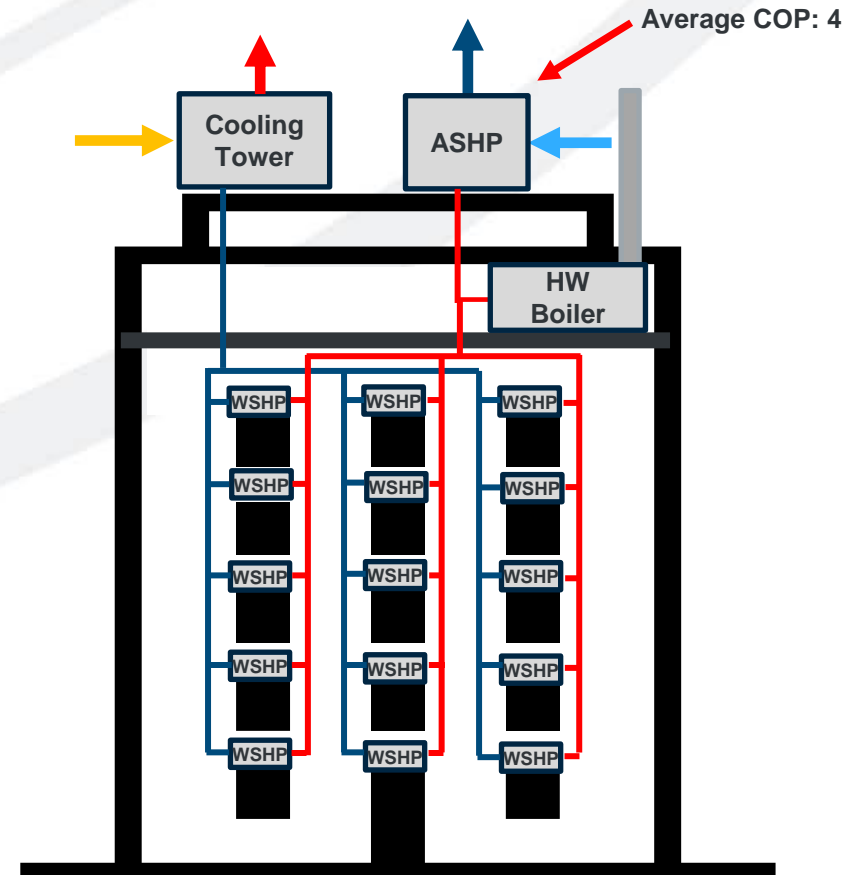

Where are we consuming fossil fuels?

- Building Heating

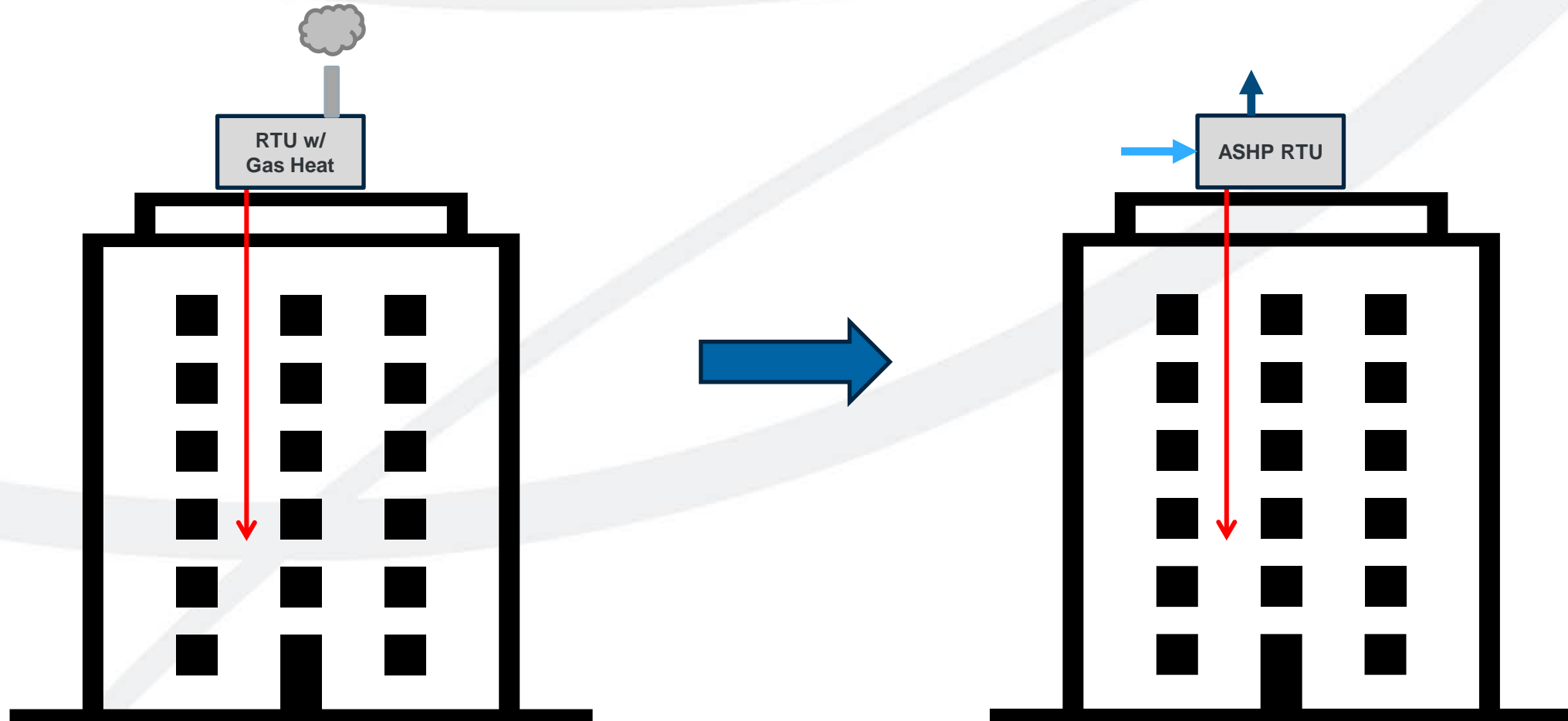

Where are we consuming fossil fuels?

- Domestic Hot Water

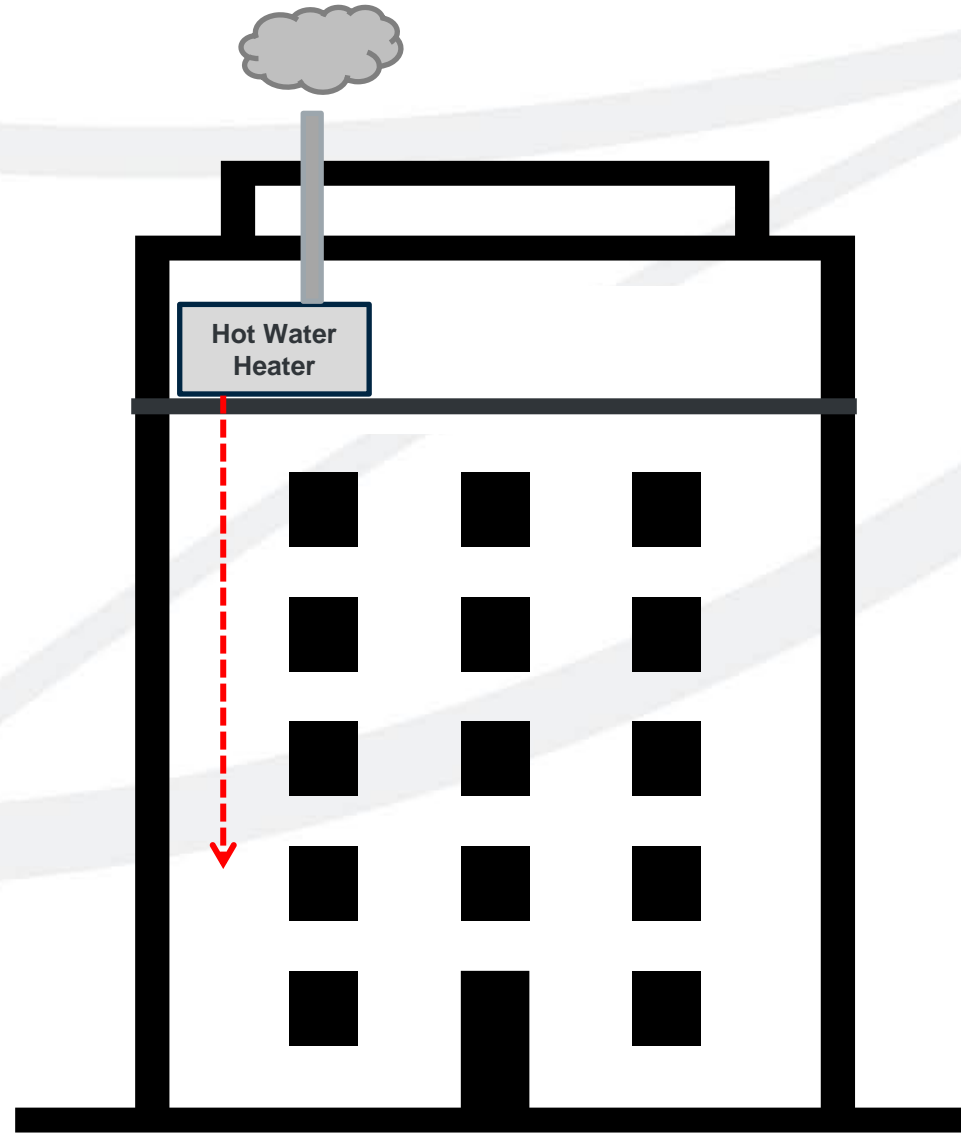

Types of Heat Pump Water Heaters

Water-Source Heat Pump

Uses a **hydronic** source to extract heat to be transferred to domestic water

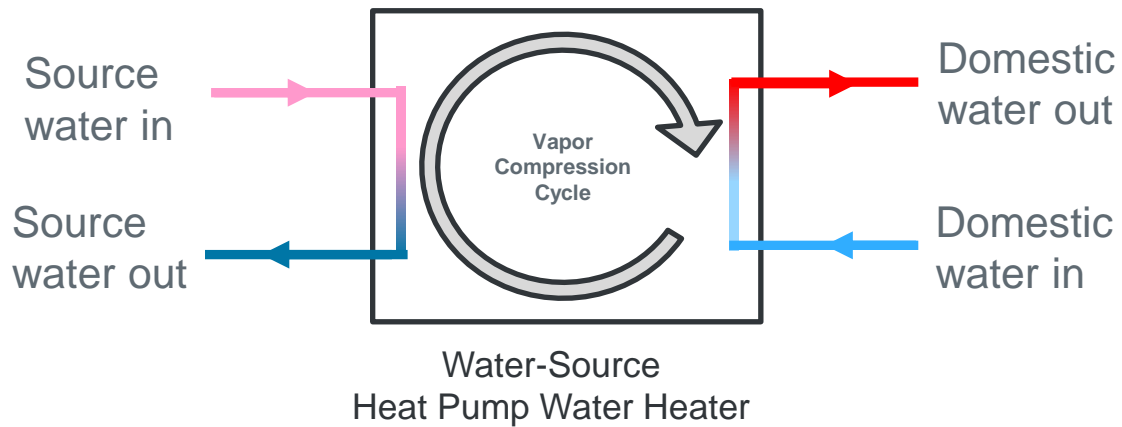

Sources of heat:

- Return CHW (in cooling season)
- Condenser water
- Geothermal

Air-Source Heat Pump

Uses an **air** source to extract heat to be transferred to domestic water

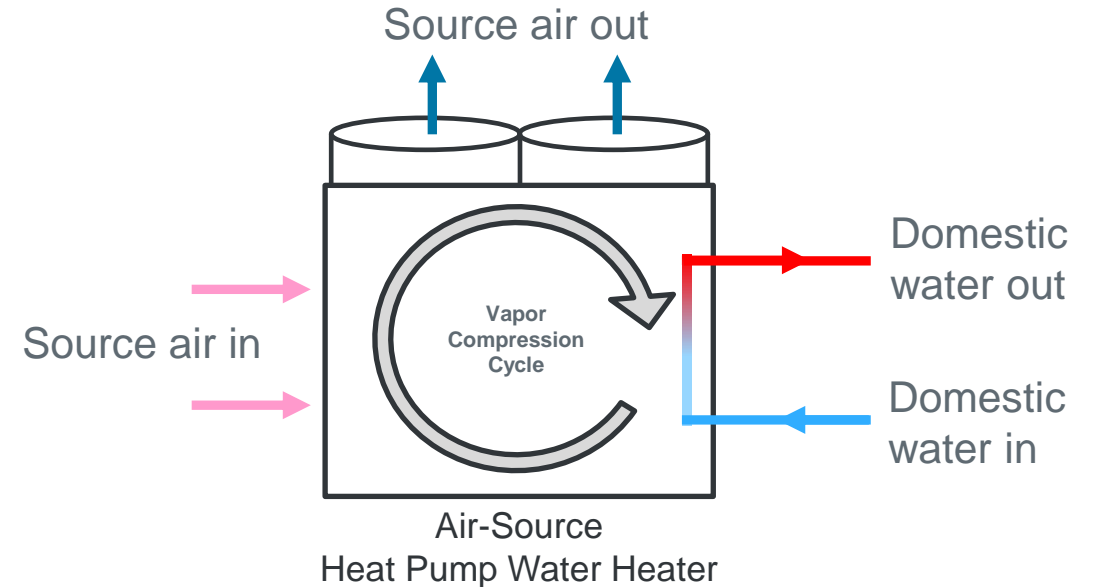

Air-Source Domestic Water Heaters

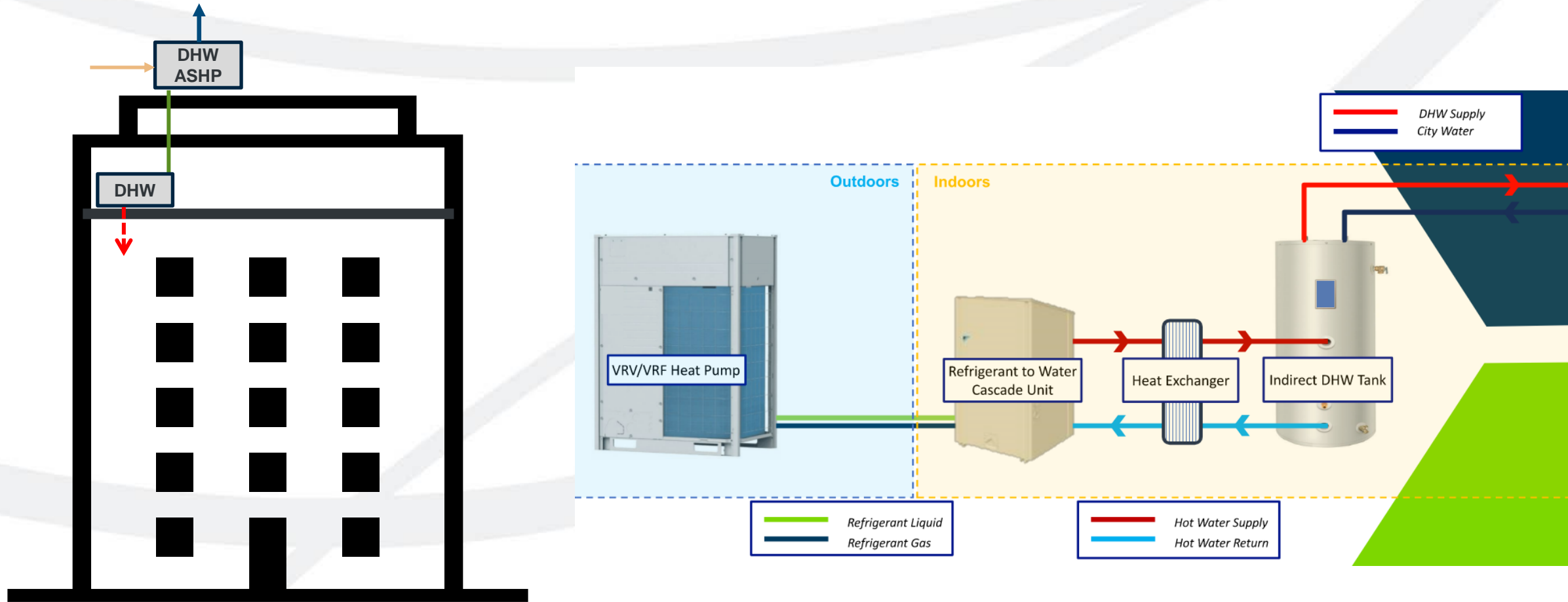

Domestic Hot Water

100% Electric vs. Hybrid

Remember this?



Now think of the ambient temperature range across a whole year – not just heating season

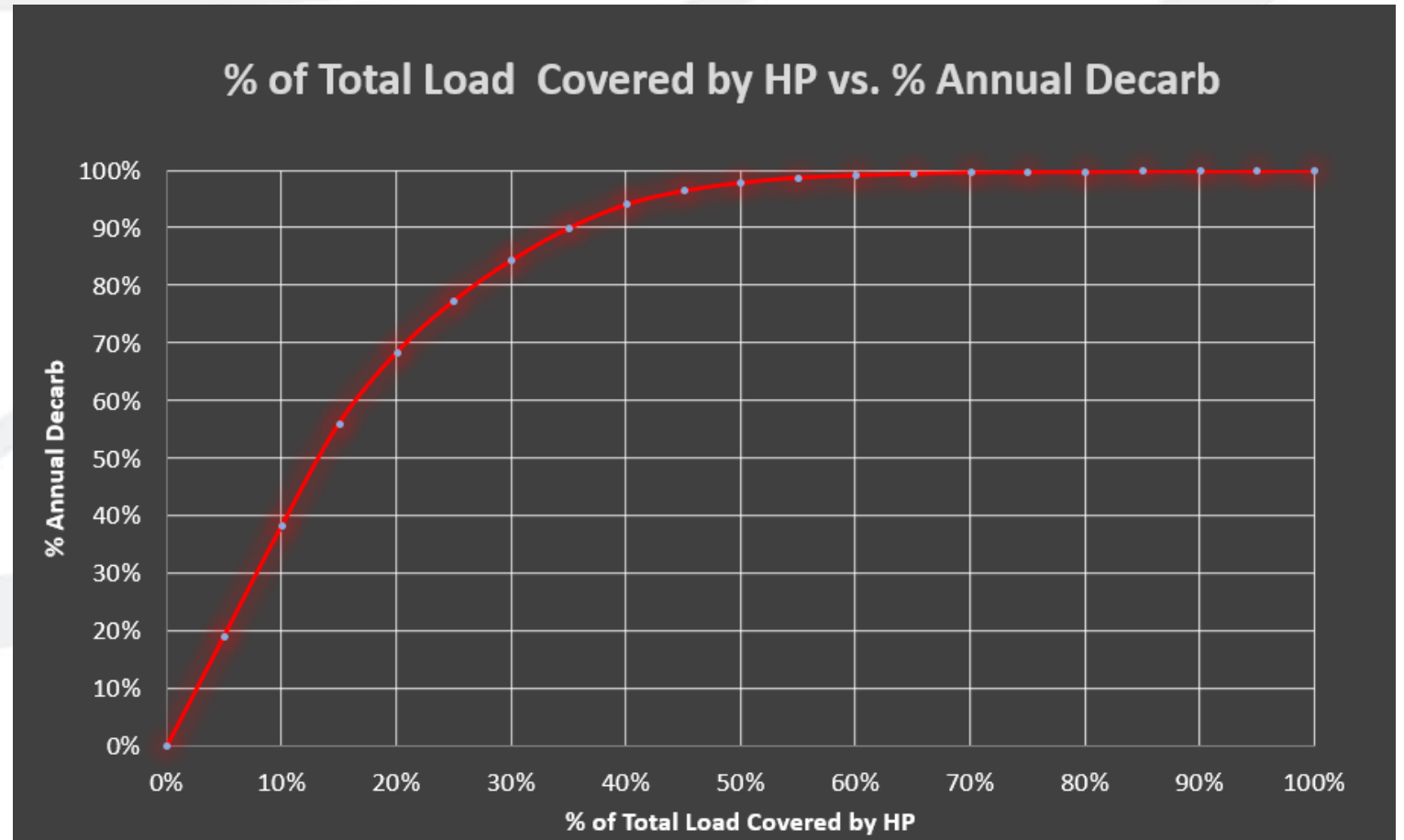

Where are we consuming fossil fuels?

- Humidification

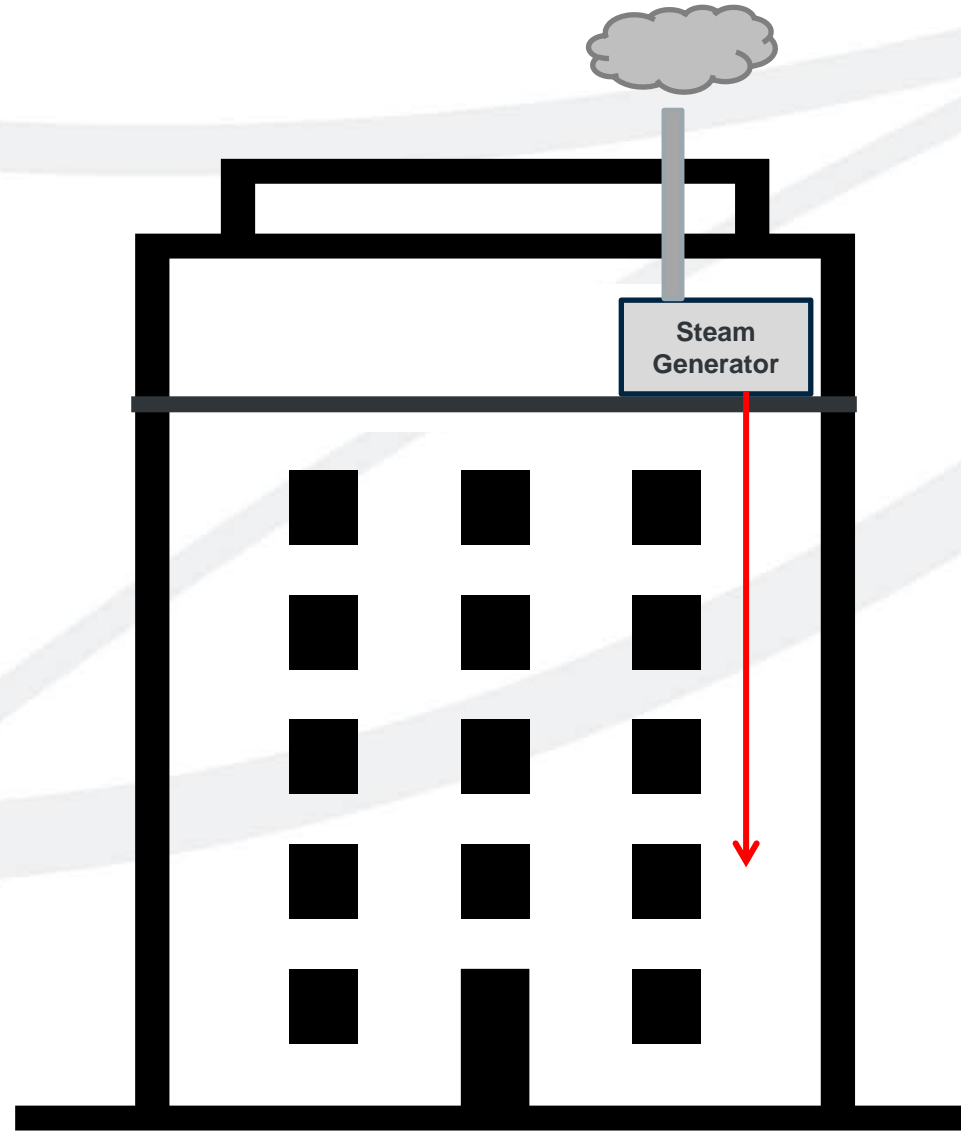

Humidification's Relation to Decarbonization

How has humidification been done in the past?

Small and Medium Scale



Electric Resistance
Atmospheric Steam
Generator



Gas-Fired Atmospheric
Steam Generator

Large Scale



Low Pressure Steam-to-Steam
Clean Steam Generator
(Fed from Gas-Fired Boiler)



Gas-Fired Clean Steam
Generator

Types of Humidification

Electric Resistance
6 - 300 lb/hr



Steam-to-Steam
15 - 1250 lb/hr



Evaporative Media

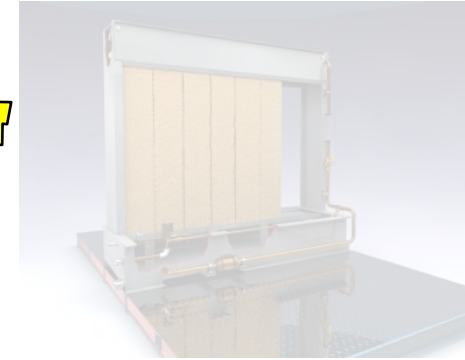

Ultrasonic
0.5 - 40 lb/hr

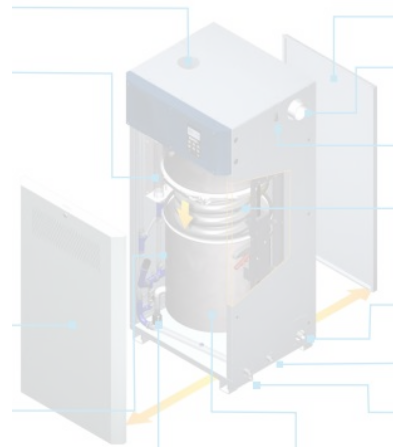

Gas-Fired
100 - 800 lb/hr



High Pressure
Atomization

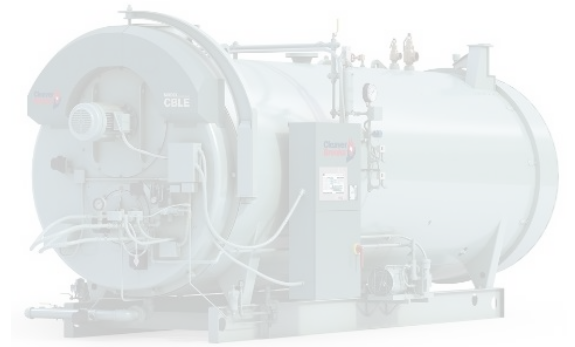

Gas-Fired LP Steam Boiler

Humidification Processes

Isothermal Humidification

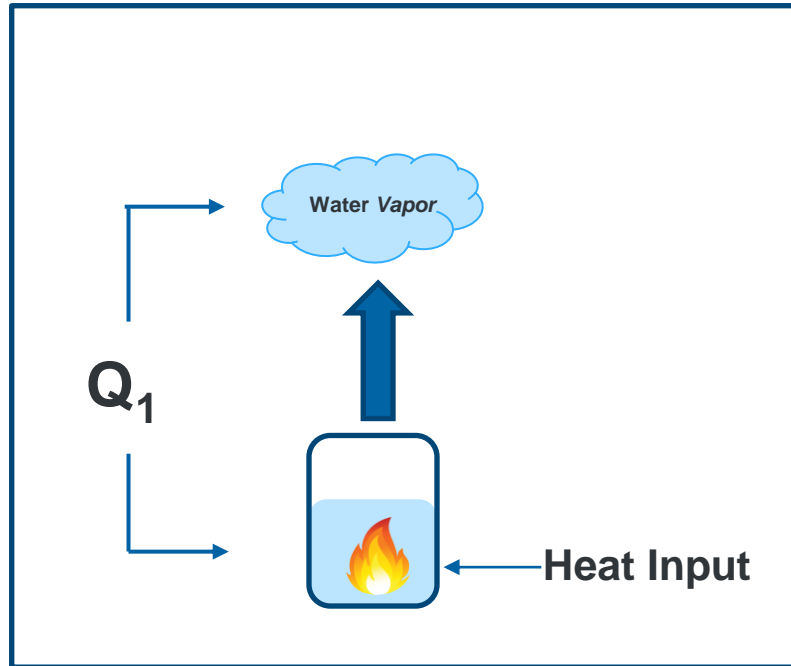

All humidifiers that generate steam
(Electric Resistance)

Adiabatic Humidification

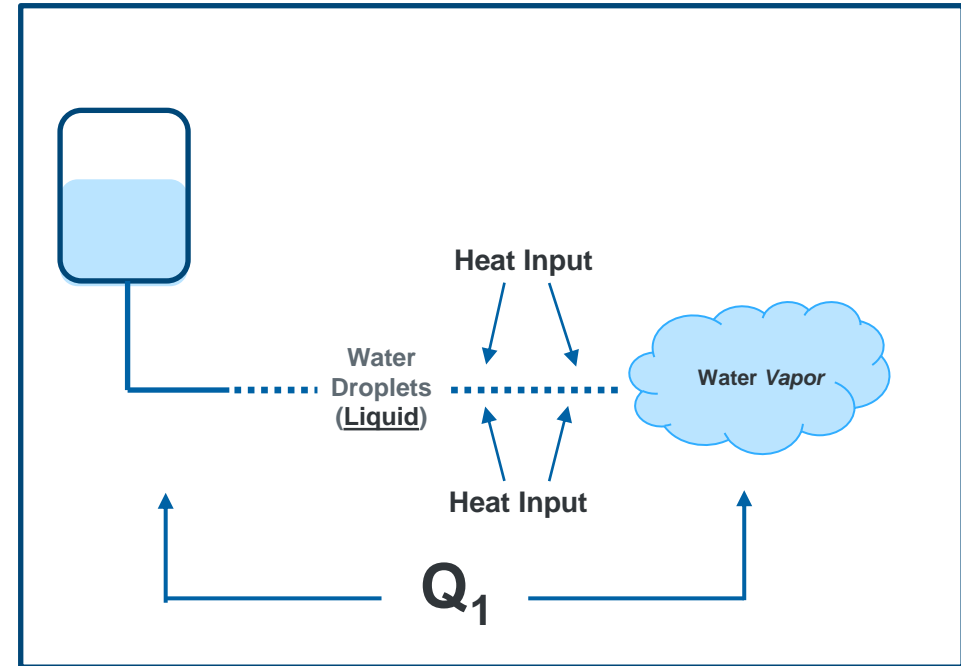

All humidifiers that do *not* generate steam
(Ultrasonic, Evaporative Media, and Fogging)

Q_1 = total energy to vaporize water = same for both methods

Humidification

High-Pressure Atomization Humidifier

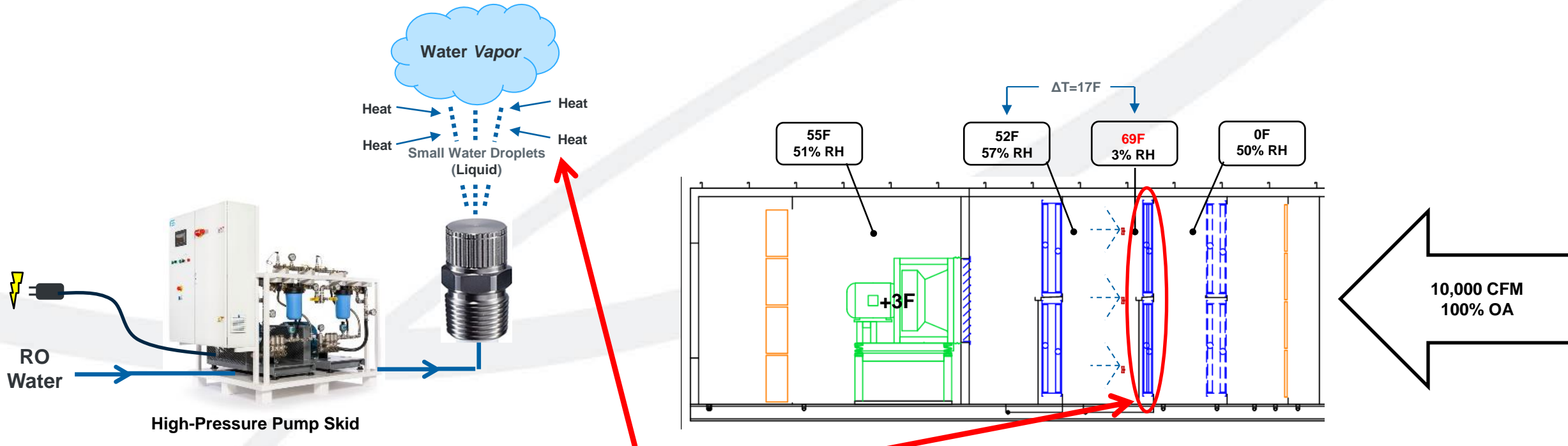

Heating coil is the energy source

What's the COP!?
It's the same COP as the heating plant

Agenda

- Part 1 – Introduction / Background
- Part 2 – Reducing Heating Loads
- Part 3 – Electrifying Heating Systems
- **Part 4 – Reducing Fan Energy**
- Part 5 – The Importance of Intelligent Building Controls

Reducing Loads from Air Movement

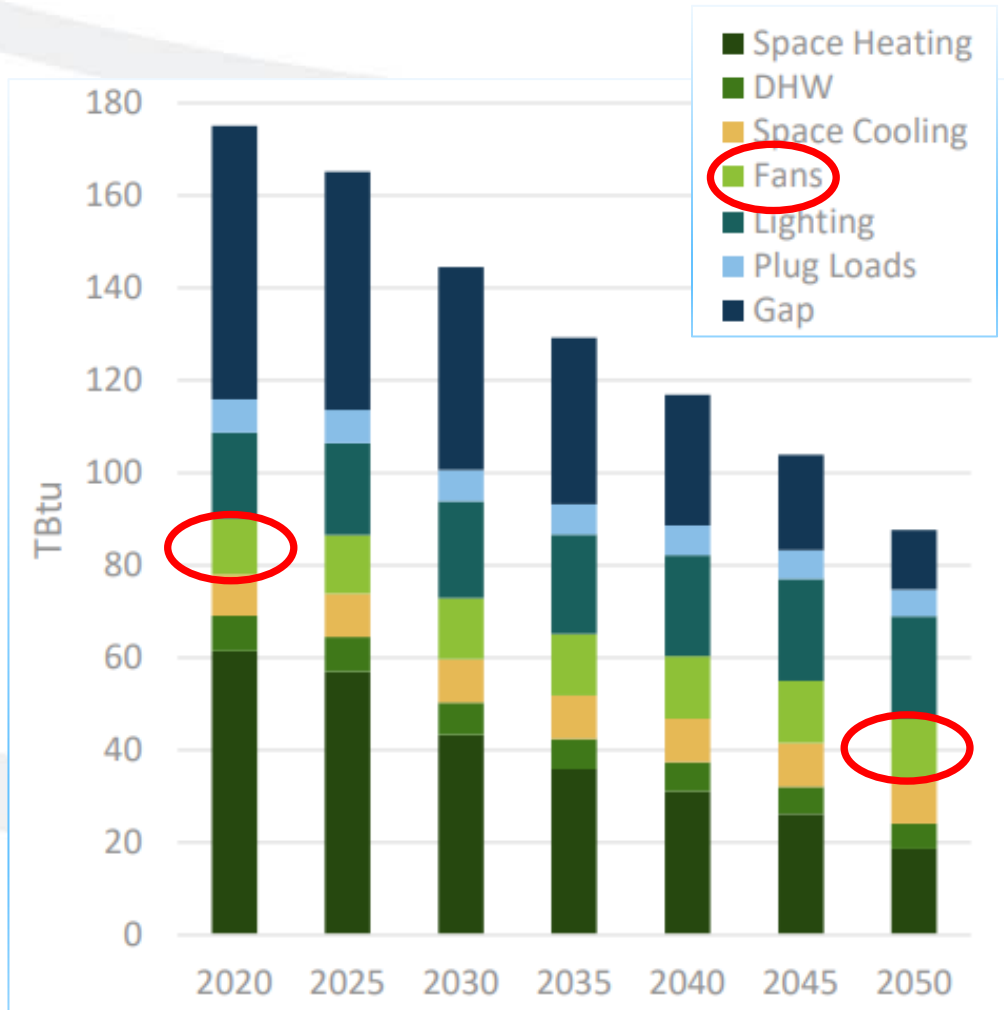

Fans were 6-7% of commercial energy demand in 2020 and, with no reduction, are predicted to become 12-13% in 2050.

Reducing Loads from Air Movement

Small / Medium Size Equipment – ECM Fan Arrays

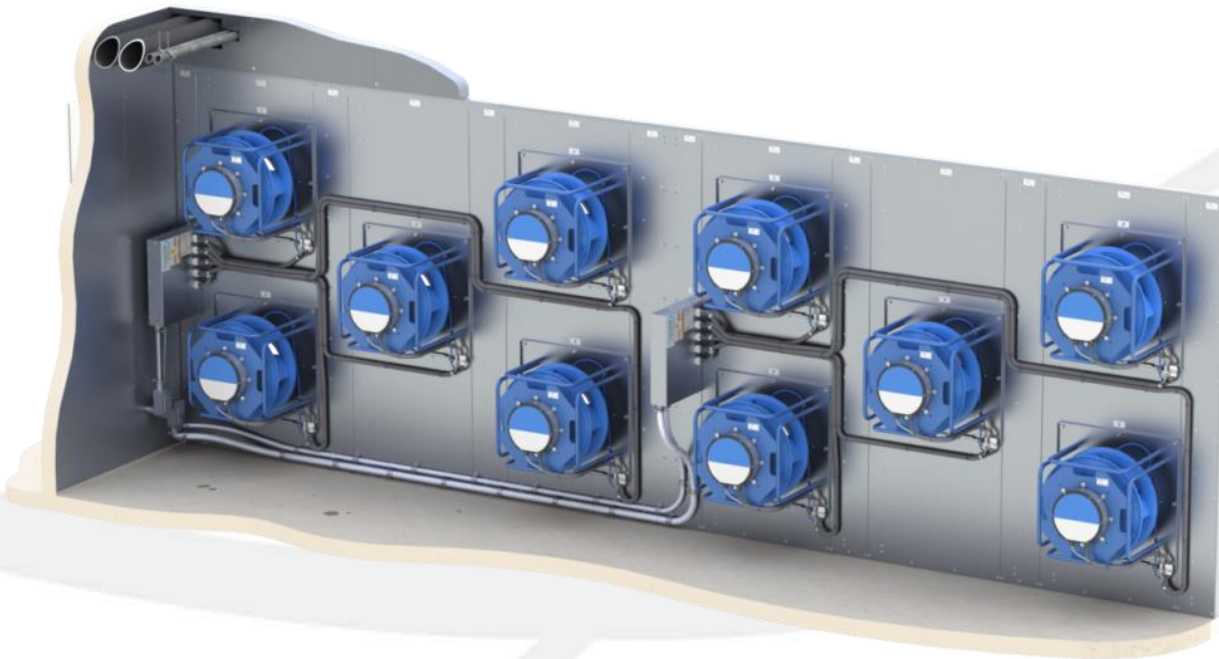

- Generally 3-5% less energy at full load and as much as 50% less energy at part load
- ECM motors excel at part loads where AC motors take on motor/VFD efficiency penalties
- Turnkey solution for owners
 - Designed for retrofits
- Great for fan retrofits – **payback can be <5 years**

Reducing Loads from Air Movement

Medium / Large Size Equipment – High-Efficiency Housed Fan Arrays



- Efficiency levels that translate to 10-20% less energy consumption when compared to standard fans
- **Higher efficiency = less load on cooling system**
- Often reduced motor sizes
 - Less connected power
 - Smaller VFD's, breakers, wire, etc.
- Integral sound attenuation, generally allowing sound attenuation to be removed from AHU's/ducts.
- Generally saves upfront cost vs. standard fans
- Good for fan retrofits – **payback can be <5 years**

Reducing Loads from Air Movement

Figure 55. Commercial Final Energy Demand by End Use, Electrification Pathway (left) and Deep Retrofit Pathway (right).

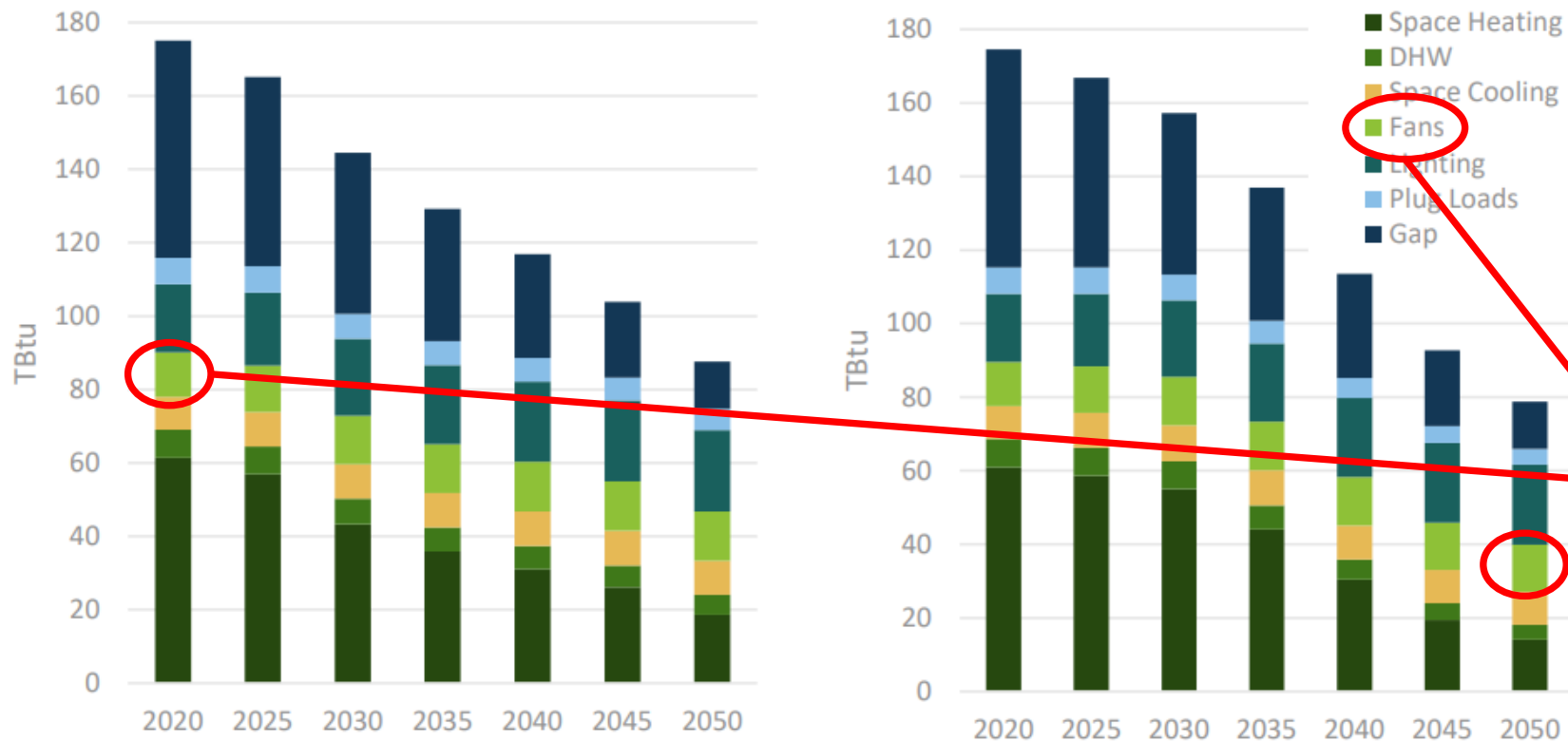

Fans were 6-7% of commercial energy demand in 2020 and, with no reduction, will become 12-13% in 2050.

High-efficiency fans can reduce overall building energy demand by ~ 1% today and ~1.7% in 2050

This can be reduced by ~13%

Closing Ventilation Control Loops

ASHRAE
GUIDELINE

ASHRAE Guideline 36-2021
(Supersedes ASHRAE Guideline 36-2018)

High-Performance Sequences of Operation for HVAC Systems

See Informative Appendix C for approval dates.

This Guideline is under continuous maintenance by a Standing Guideline Project Committee (SGPC) for which the Standards Committee has established a documented program for regular publication of addenda or revisions, including procedures for timely, documented, consensus action on requests for change to any part of the Guideline. Instructions for how to submit a change can be found on the ASHRAE® website (<https://www.ashrae.org/continuous-maintenance>).

The latest edition of an ASHRAE Guideline may be purchased from the ASHRAE website (www.ashrae.org) or from ASHRAE Customer Service, 1791 Tullie Circle, NE, Atlanta, GA 30329-2305. E-mail: orders@ashrae.org. Fax: 678-539-2129. Telephone: 404-636-8400 (worldwide), or toll free 1-800-527-4723 (for orders in US and Canada). For reprint permission, go to www.ashrae.org/permissions.

© 2021 ASHRAE ISSN 1049-894X

Automation 101

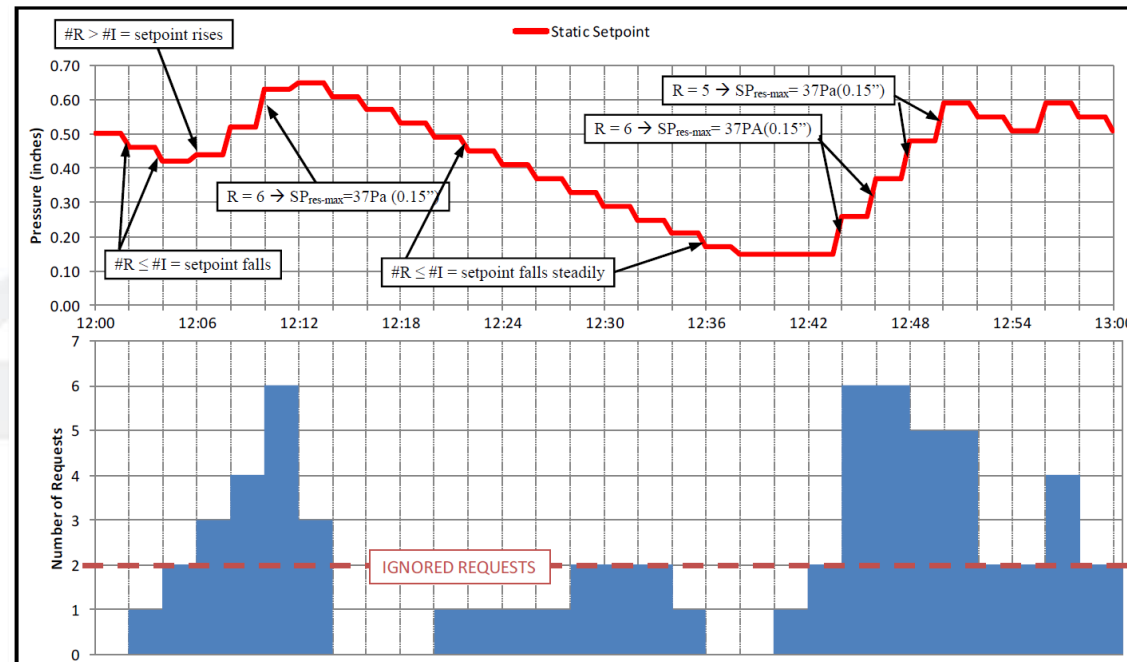
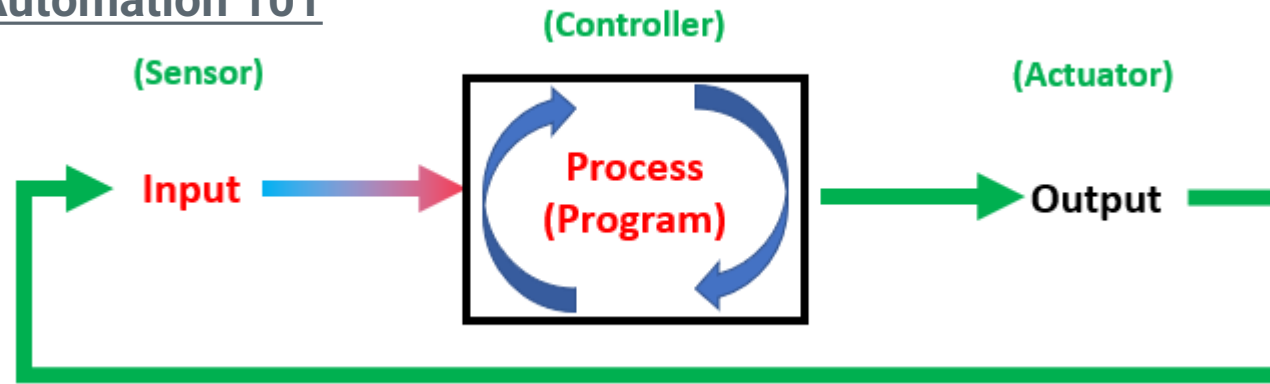

Trim and Respond

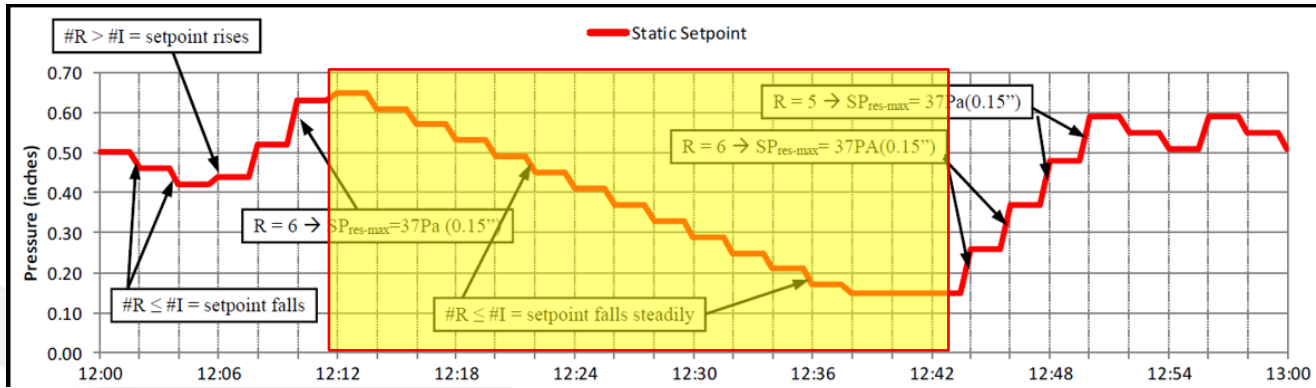
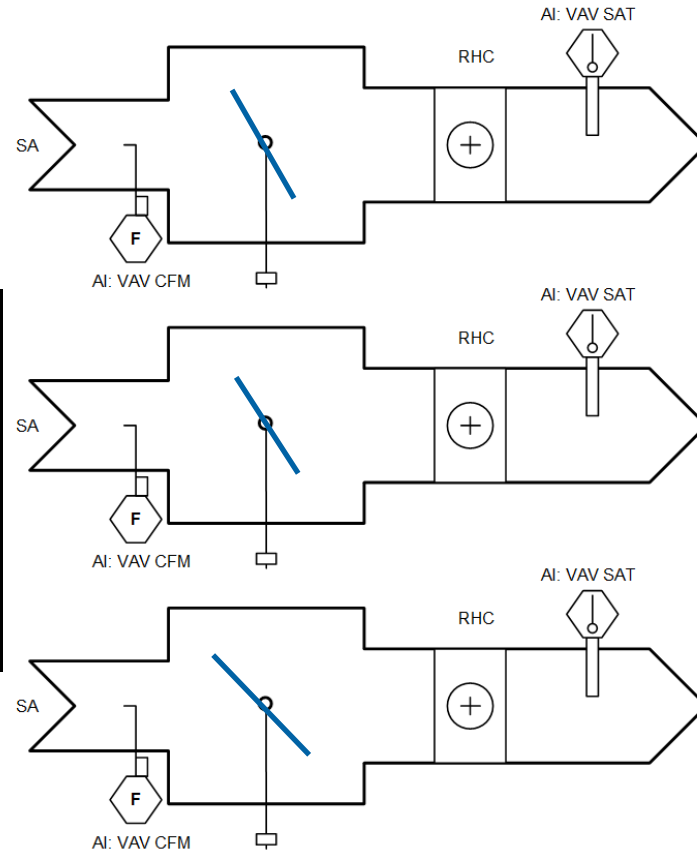
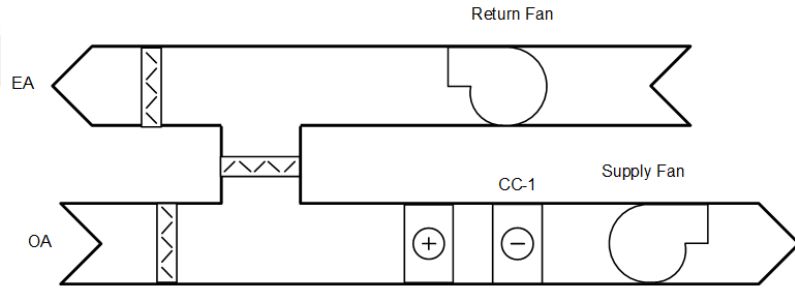

Trim

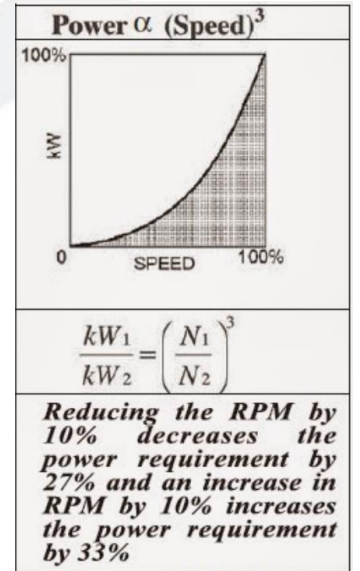
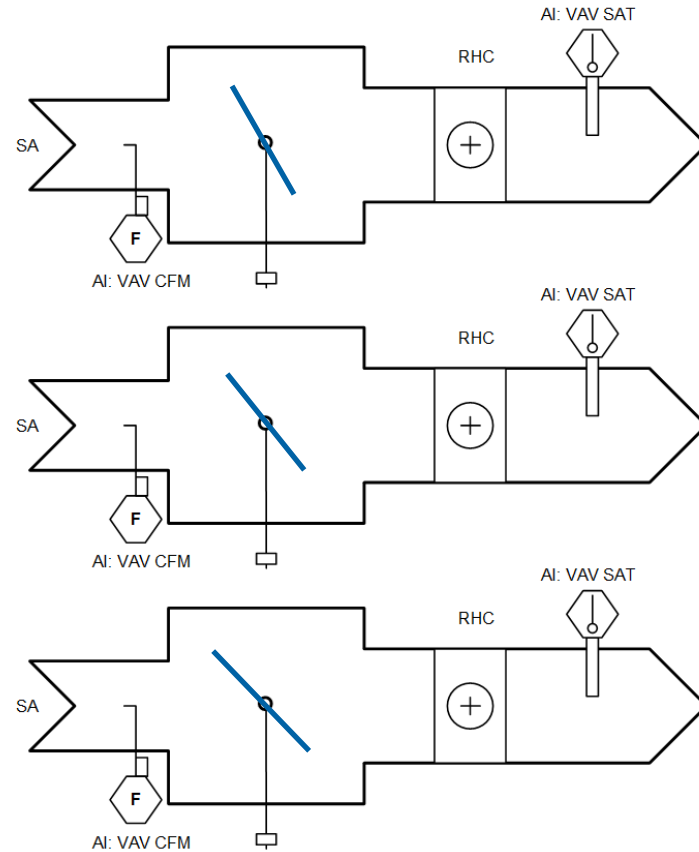
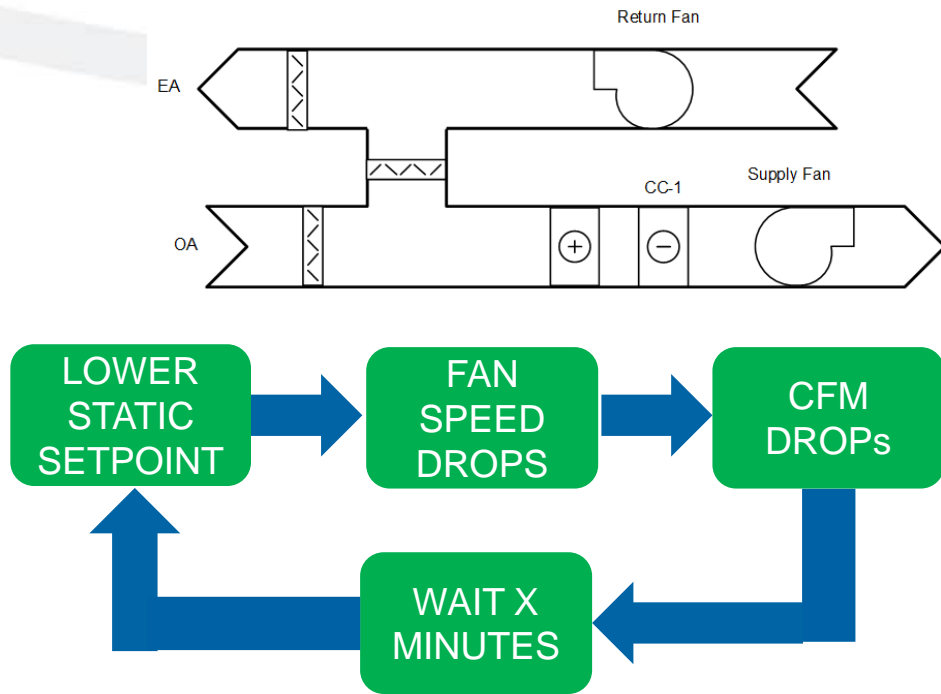

Trim

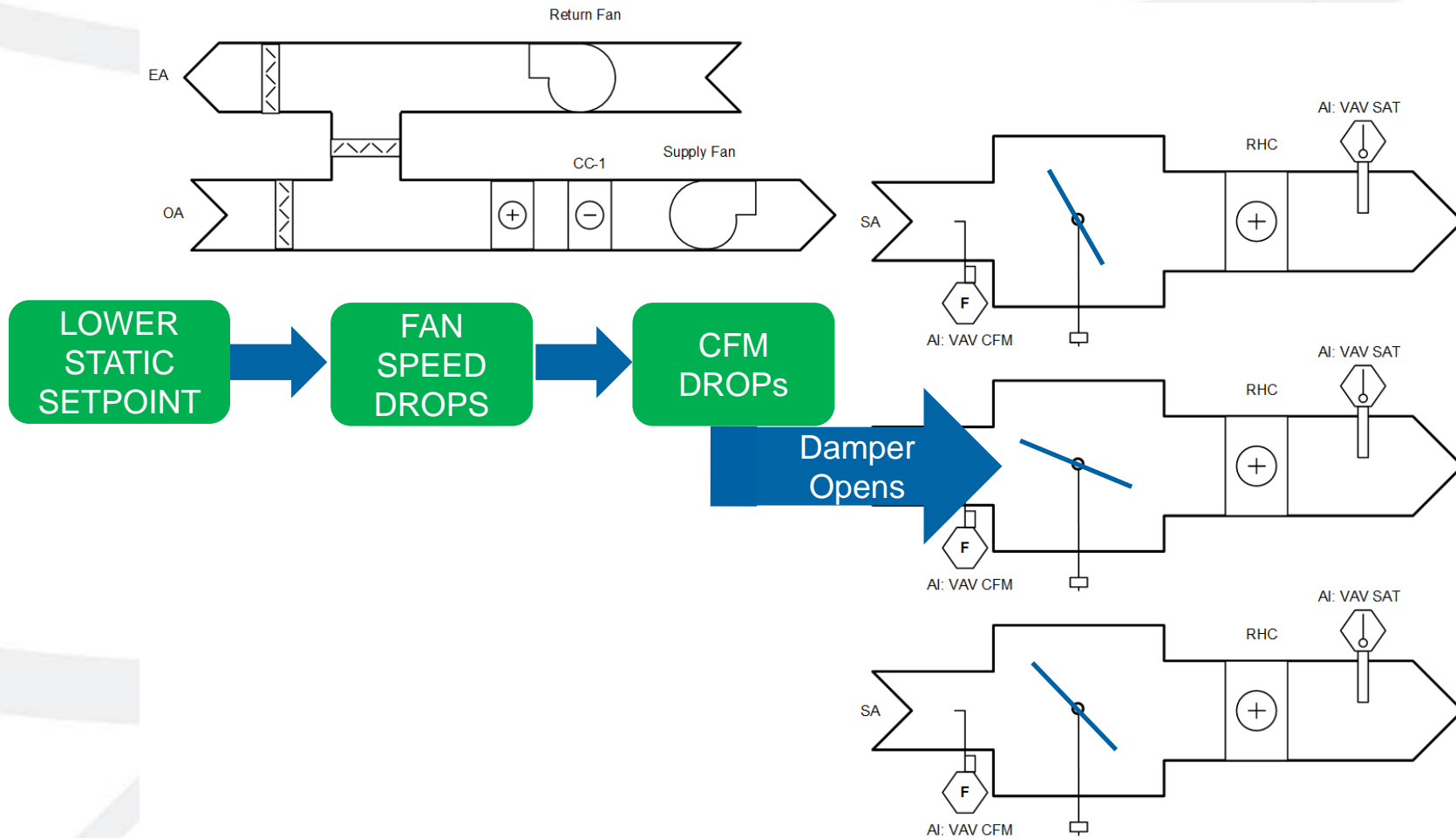

Response Generated

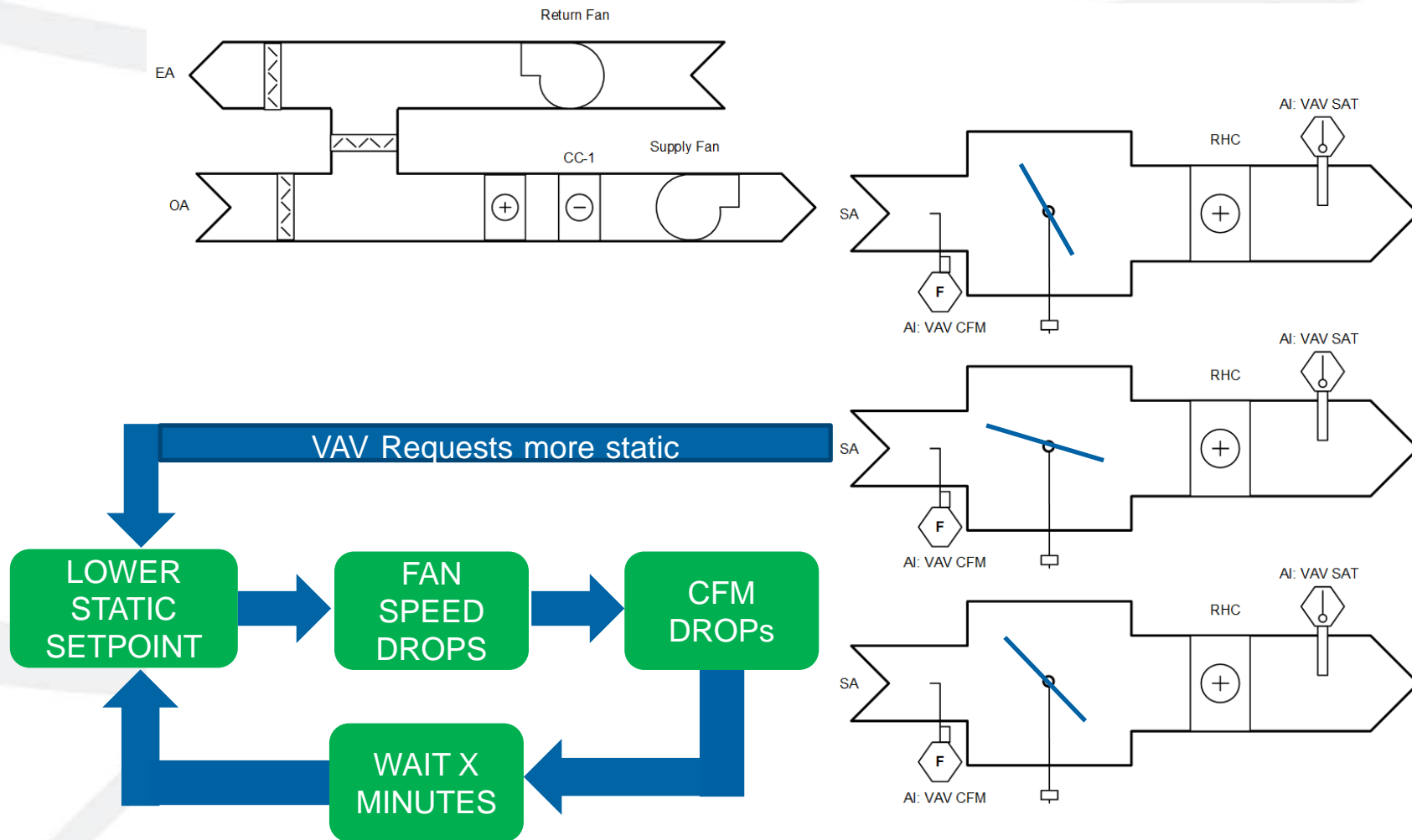

Trim until enough response occurs

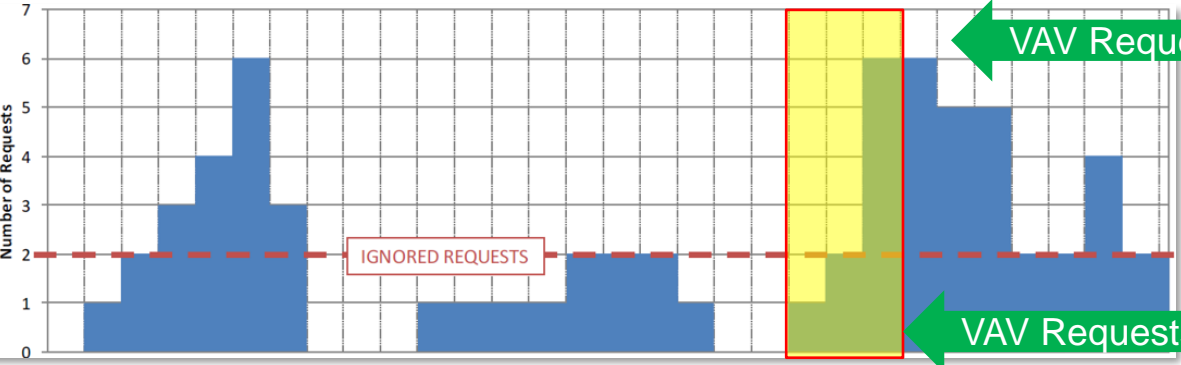
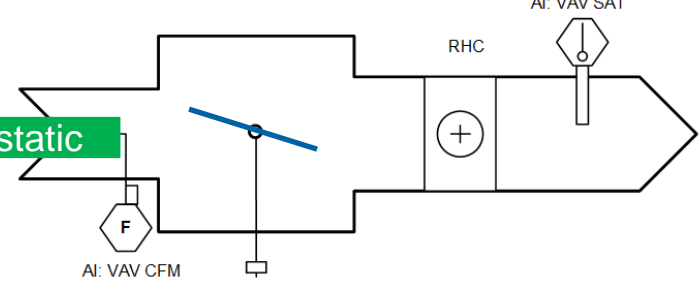
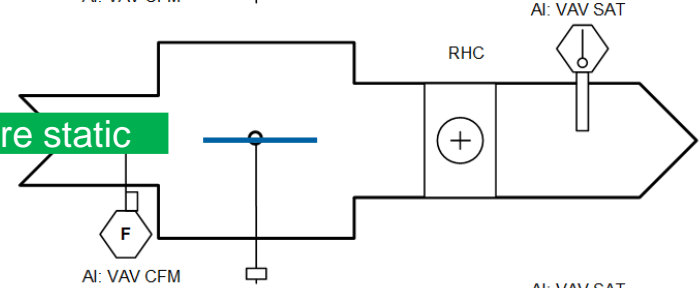
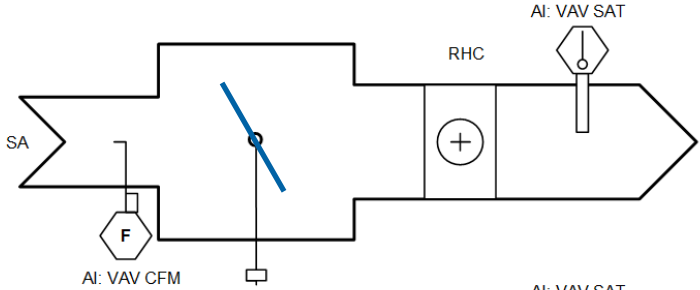
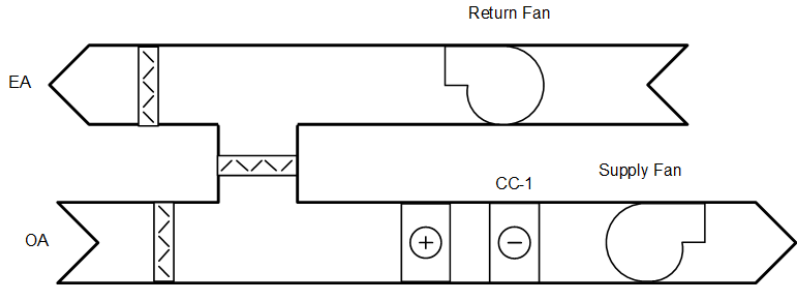

VAV Requests more static

VAV Requests more static

Respond – Closed Loop Control!

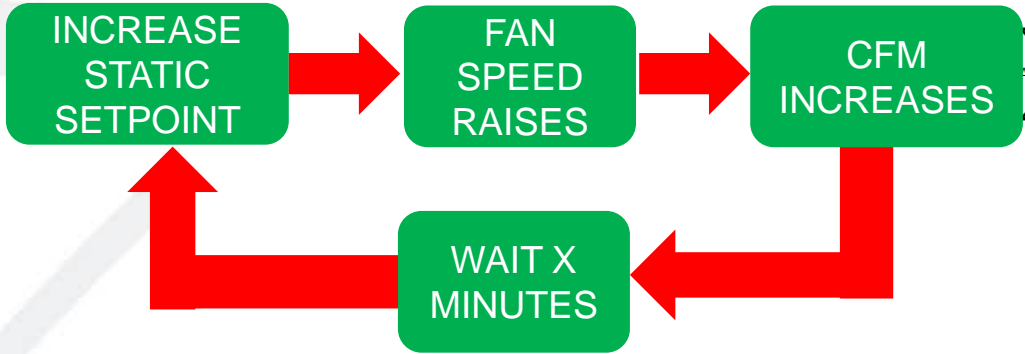
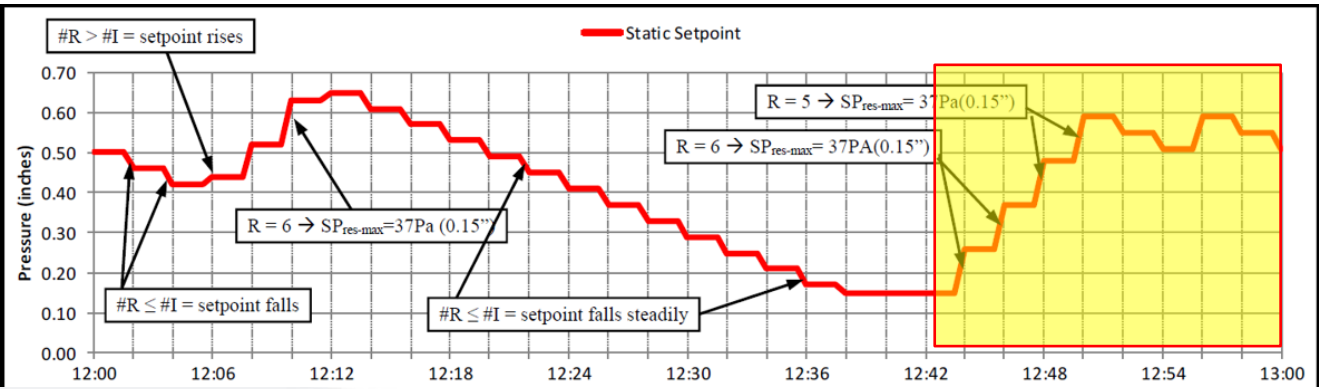
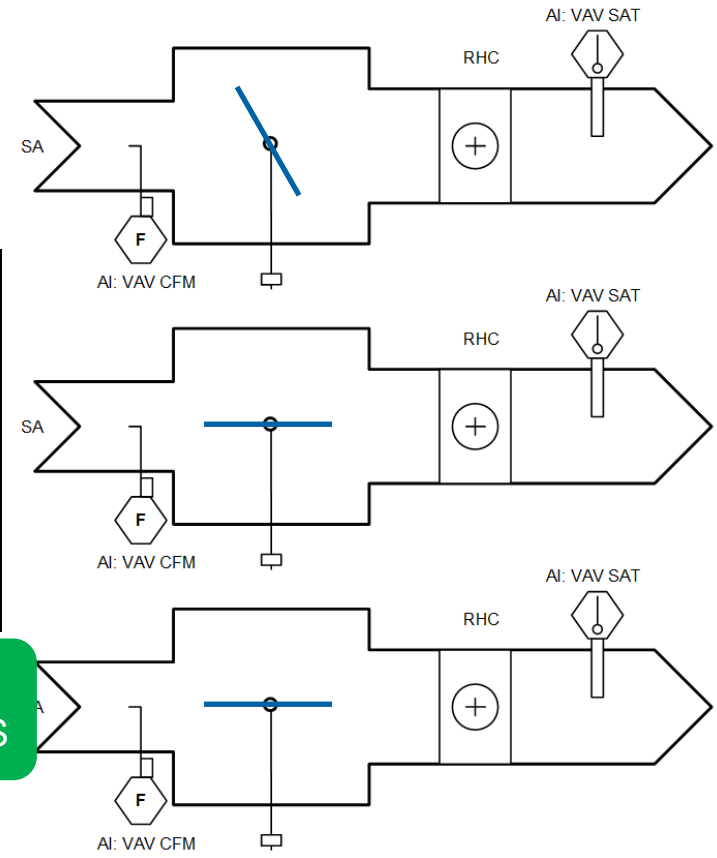
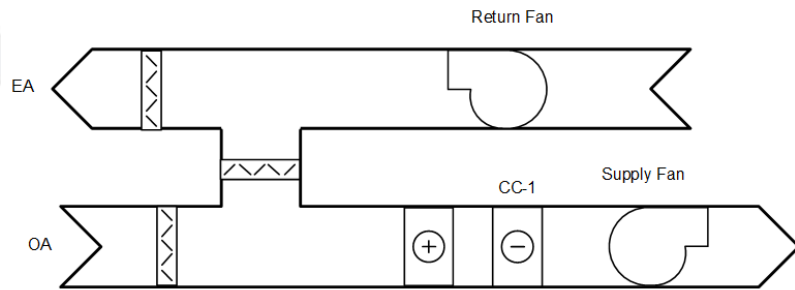

Agenda

- Part 1 – Introduction / Background
- Part 2 – Reducing Heating Loads
- Part 3 – Electrifying Heating Systems
- Part 4 – Reducing Fan Energy
- **Part 5 – The Importance of Intelligent Building Controls**

BAS Architecture

Enterprise



Server

Building (Global Control)



Building A



Building B

Equipment (AHU/Plant Control)



AHU-1



AHU-2



AHU-1



Central
Plant

Sensors and Actuators (Device Control)



Field Devices

Distributed Controls Architecture

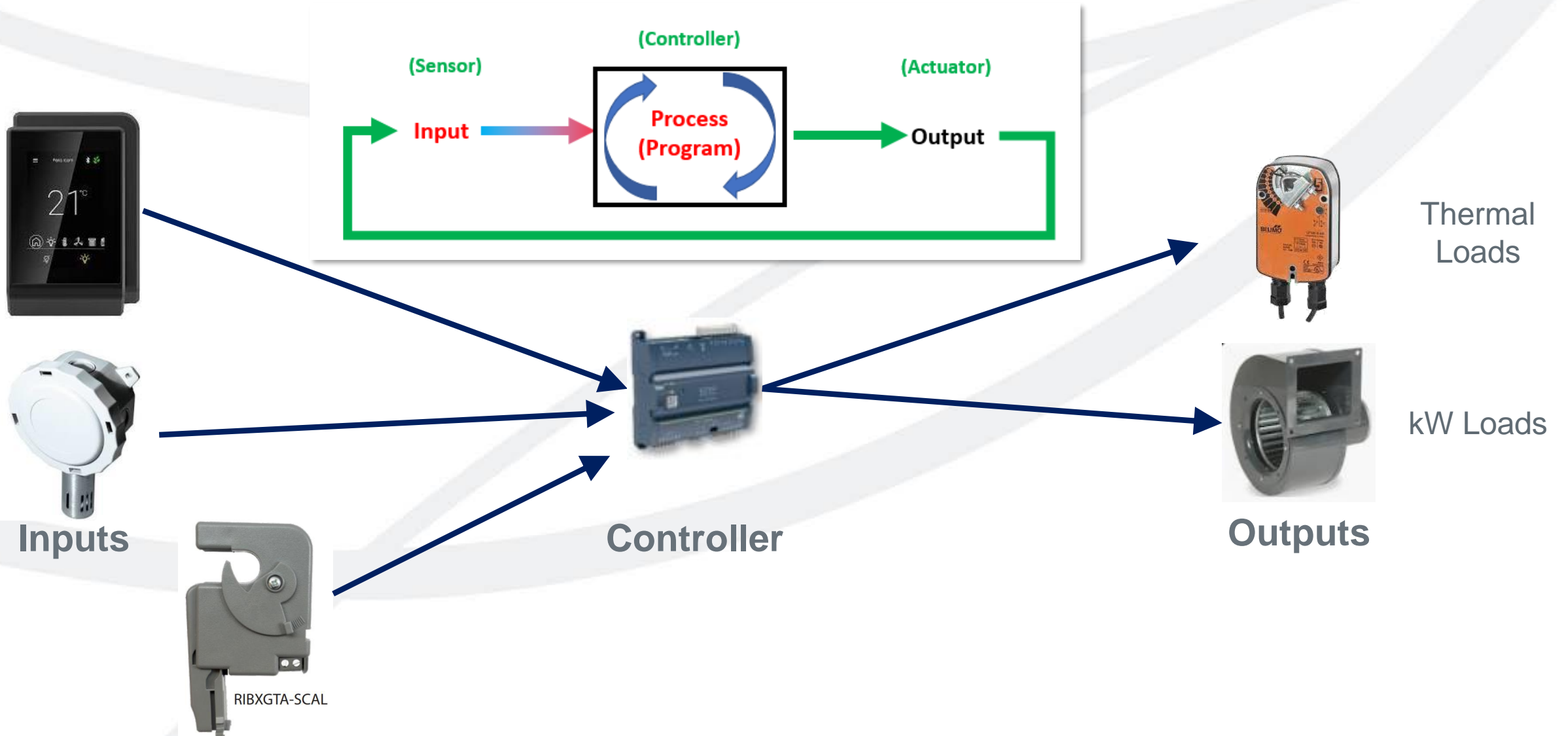

Controls - Where do we start?

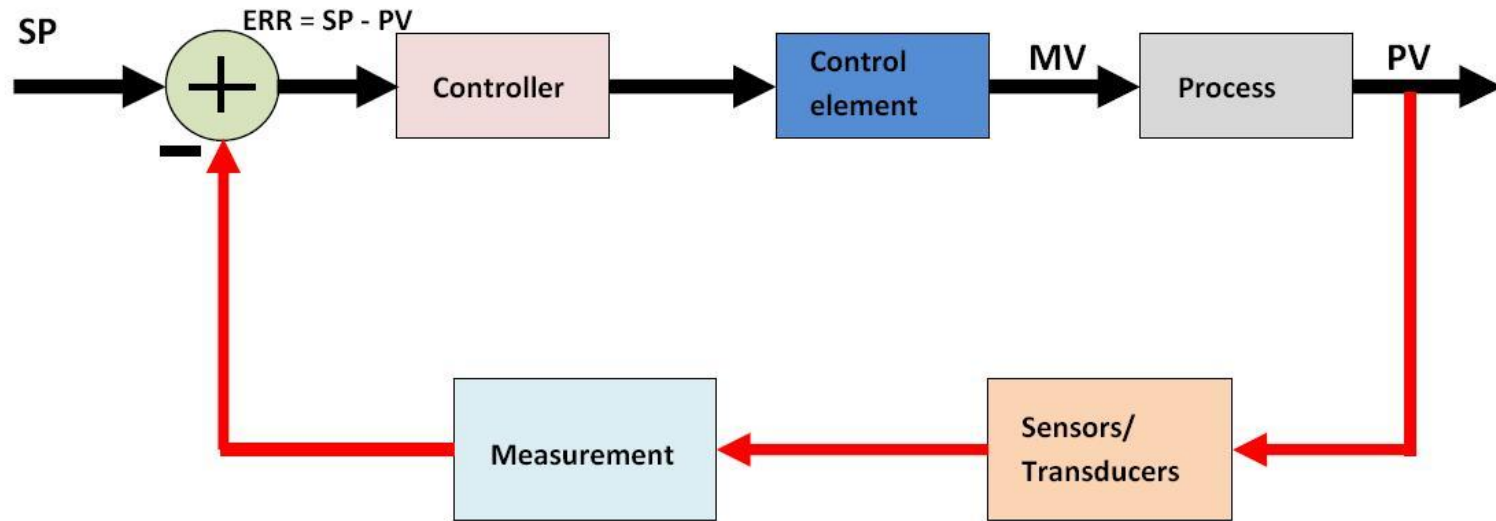

Every good controls engineer will utter this sacred phrase:
“You cannot control what you’re not measuring”

Distributed Controls Architecture

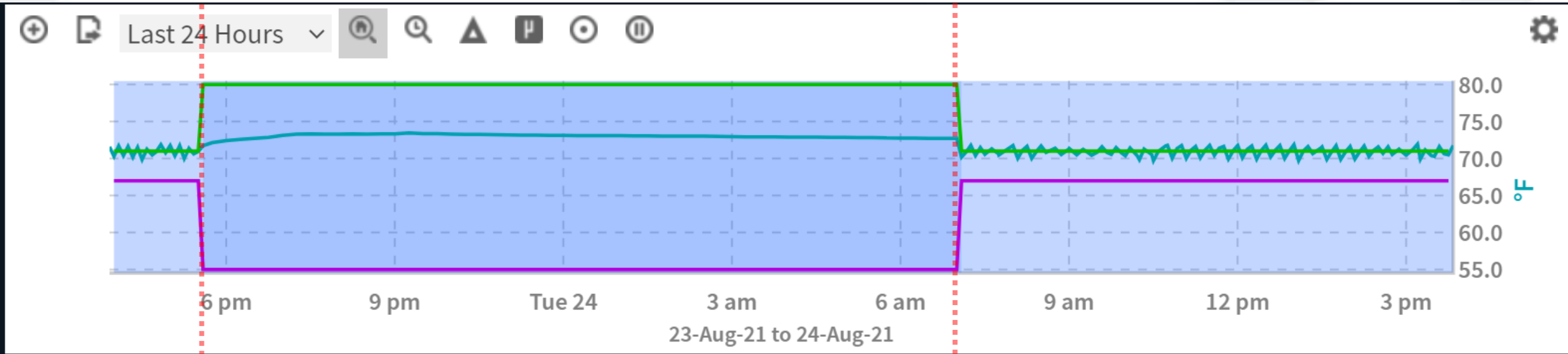

Occupied

- Fan On

Unoccupied

- Fan off

Occupied

- Fan On
- Valve or Compressor Cycling to maintain cooling setpoint

Control Loops:

- Ventilation – Scheduled, Open Control Loop
- Thermal – Compressor / Valve, Closed Control Loop

Current Methods – Monthly Billing = Metering



Inputs for CO₂e

- Electrical
- Fossil Fuel heat
- Domestic Water

Issues:

- 12 data points per year
- Read by humans
- Time delayed

Government Ordinance Requirements

ENERGY STAR
PortfolioManager

Welcome | Account | Notifications | ENERGY STAR | Contacts | Help | Sign Out
arianaaxelrod: Settings | Notifications

MyPortfolio | Sharing | Reporting | Recognition

EPA Sample University

314 Einstein Place, Springfield, VT 05156 | [Map It](#)
Portfolio Manager Property ID: 33105685
Year Built: 1901
[Edit](#)

Not currently eligible for ENERGY STAR Certification

Weather Normalized Source EUI (kBtu/ft²)

Current: 155.9
(13.66% lower than median.)

Baseline: 165.7
(8.25% lower than median.)

[Change Metric](#)

Summary | Details | Energy | Water | Waste & Materials | Goals | Design

Source EUI Trend (kBtu/ft²)

[Change Metric](#)

(Chart current as of 03/07/2024 07:26 PM EST) [Refresh Chart](#)

Metrics Summary

[Change Metrics](#)
[Change Time Periods](#)

Metric	Dec 2014 (Energy Baseline)	Mar 2017 (Energy Current)	Change
ENERGY STAR Score (1-100)	Not Available	Not Available	N/A
Source EUI (kBtu/ft ²)	167.5	154.9	-12.60 (-7.50%)
Site EUI (kBtu/ft ²)	81.1	70.5	-10.60 (-13.10%)
Energy Cost (\$)	3,040,941.24	2,807,209.75	-233,731.49 (-7.70%)
Total (Location Based) GHG Emissions Intensity (kgCO ₂ e/ft ²)	5.4	4.8	-0.60 (-11.10%)
Water Use (All Water Sources) (kgal)	87,634.4	90,491.1	2,856.70 (3.30%)
Total Waste (Disposed and Diverted) (Ton)	3,823.93	3,141.05	-682.88 (-17.90%)

Long Term Planning for 2050 requires Data!

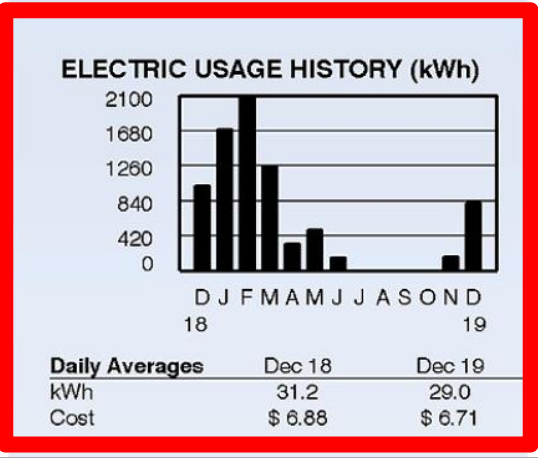
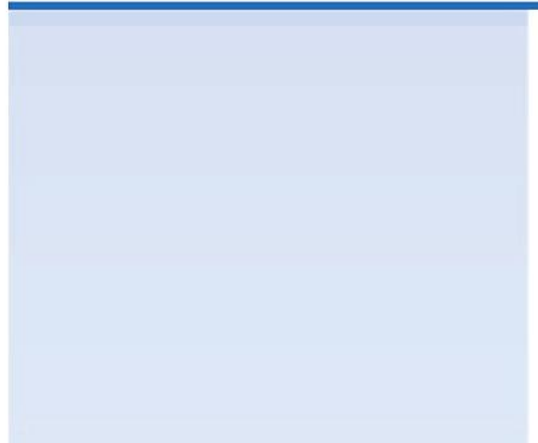
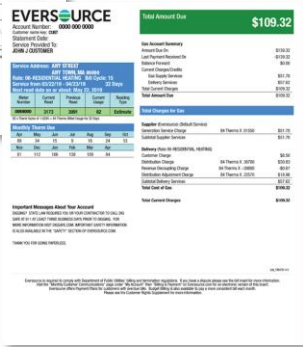
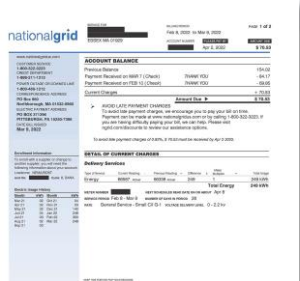

DETAIL OF CURRENT CHARGES

Delivery Services

Service Period	No. of days	Current Reading	Previous Reading
Oct 29 - Nov 26	28	14061 Actual	13248 Actual

METER NUMBER 12345678 NEXT SCHEDULED READ DATE ON OR ABOUT Dec 31

RATE Residential Regular R-1

Customer Charge		
Dist Chg	0.06705424 x	813 kWh
Transition Charge	-0.00103 x	813 kWh
Transmission Charge	0.03164 x	813 kWh
Energy Efficiency Chg	0.01805 x	813 kWh
Renewable Energy Chg	0.0005 x	813 kWh
Distributed Solar Charge	0.00146 x	813 kWh

Total Delivery Services

Permanent Submetering has lots of value

12 Data points per year

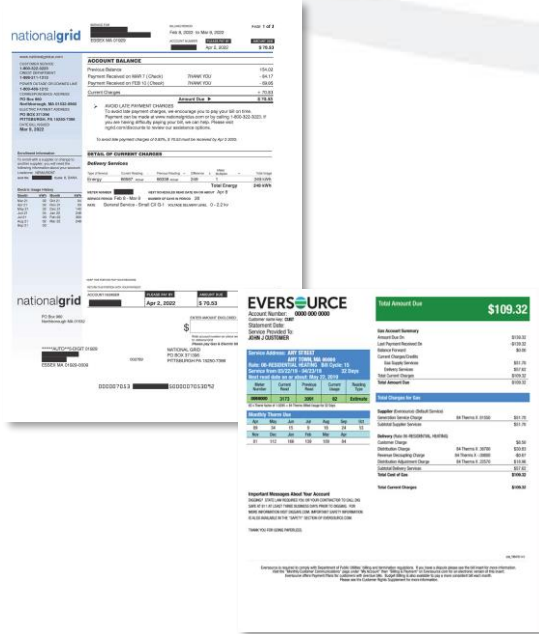

CURRENT TRANSACTIONS		PAYMENTS RECEIVED	
SERVICE CHARGES	\$18.83	09/23/2018 Payment	\$5.21 CR
Water usage	\$22.22	TOTAL PAYMENTS RECEIVED	\$5.21 CR
Sewer usage	\$68.79		
TOTAL SERVICE CHARGES	\$109.84		
TOTAL CURRENT CHARGES	\$109.84		

35k Data points per year



BAS occupancy

Actual Building occupancy

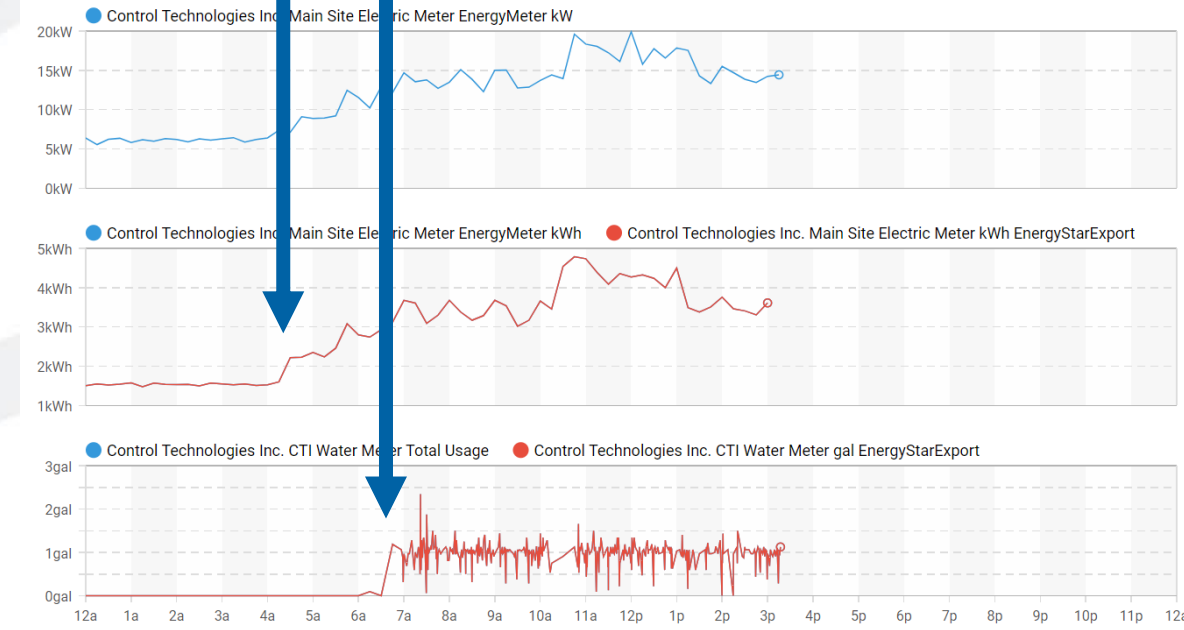

Uncover Hidden Energy Hogs!

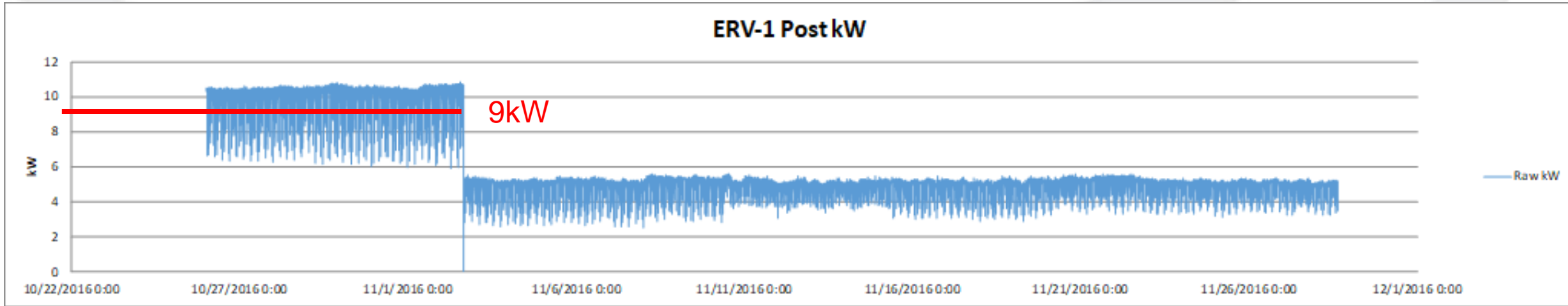

Ventilation for Hotel, runs 24/7, 365

Uncover Hidden Energy Hogs!

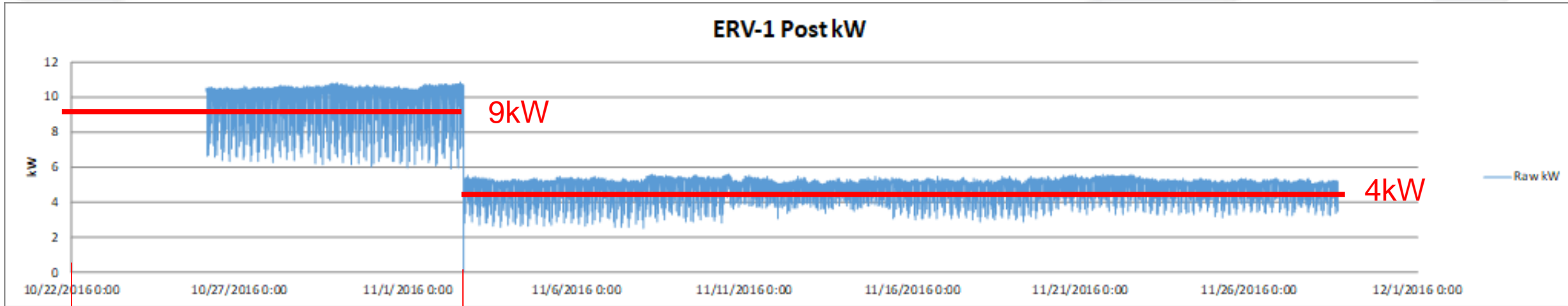

Ventilation for Hotel, runs 24/7, 365

$8760 \text{ hours} * 9\text{kW} = 78,840 \text{ kWh}$

@ \$0.17 kWh, that's ~ \$13,400 Annually

Uncover Hidden Energy Hogs!

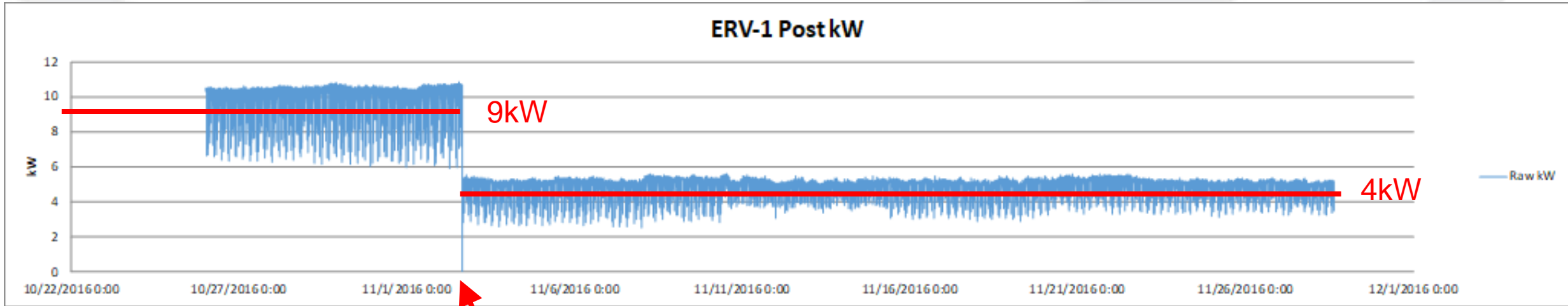

Uncover Hidden Energy Hogs!

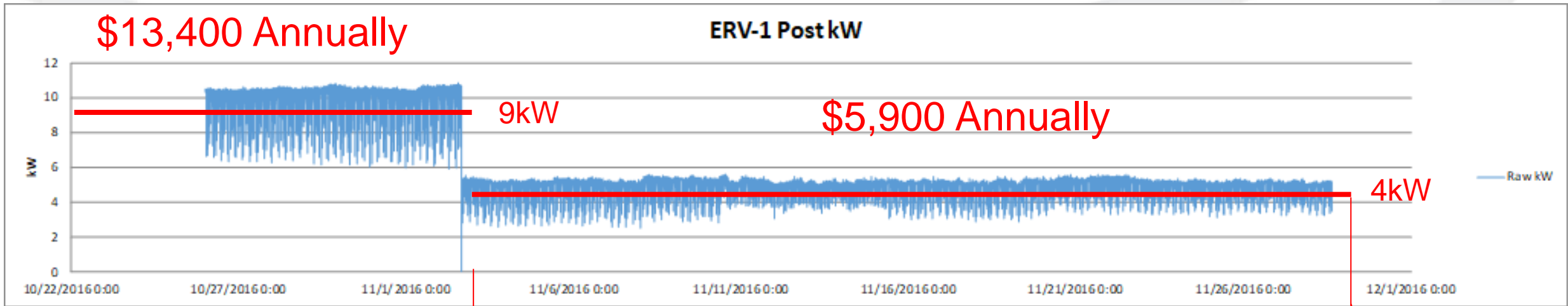

8760 hours * 4kW = 35,040 kWh
@ \$0.17 kWh, that's ~ \$5,900 Annually
~\$7,500 annual savings, 56% reduction!

Uncover Hidden Energy Hogs!

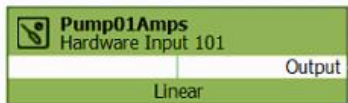
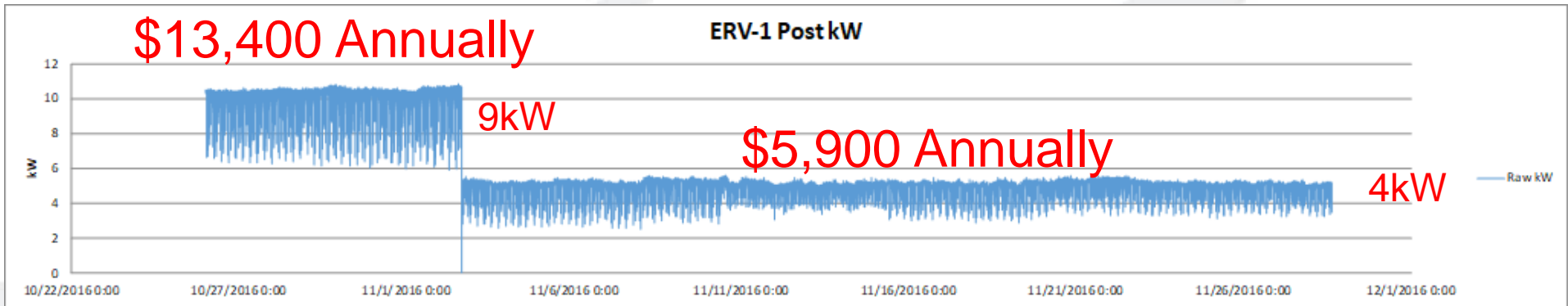
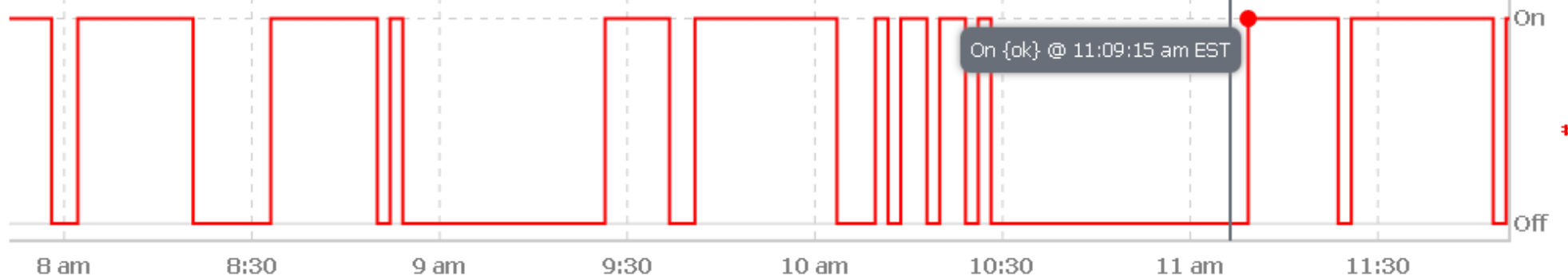
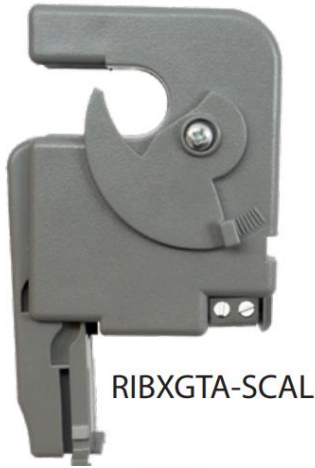

0.023... A

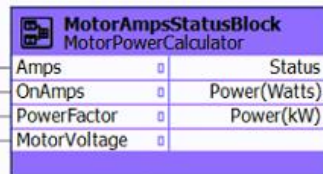
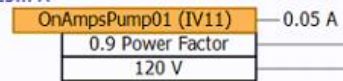

FALSE (0)

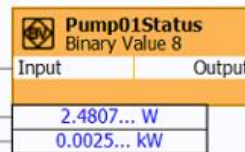

Pump01Status

Measure Current, and determine "equipment status" – on/off above "X" amps

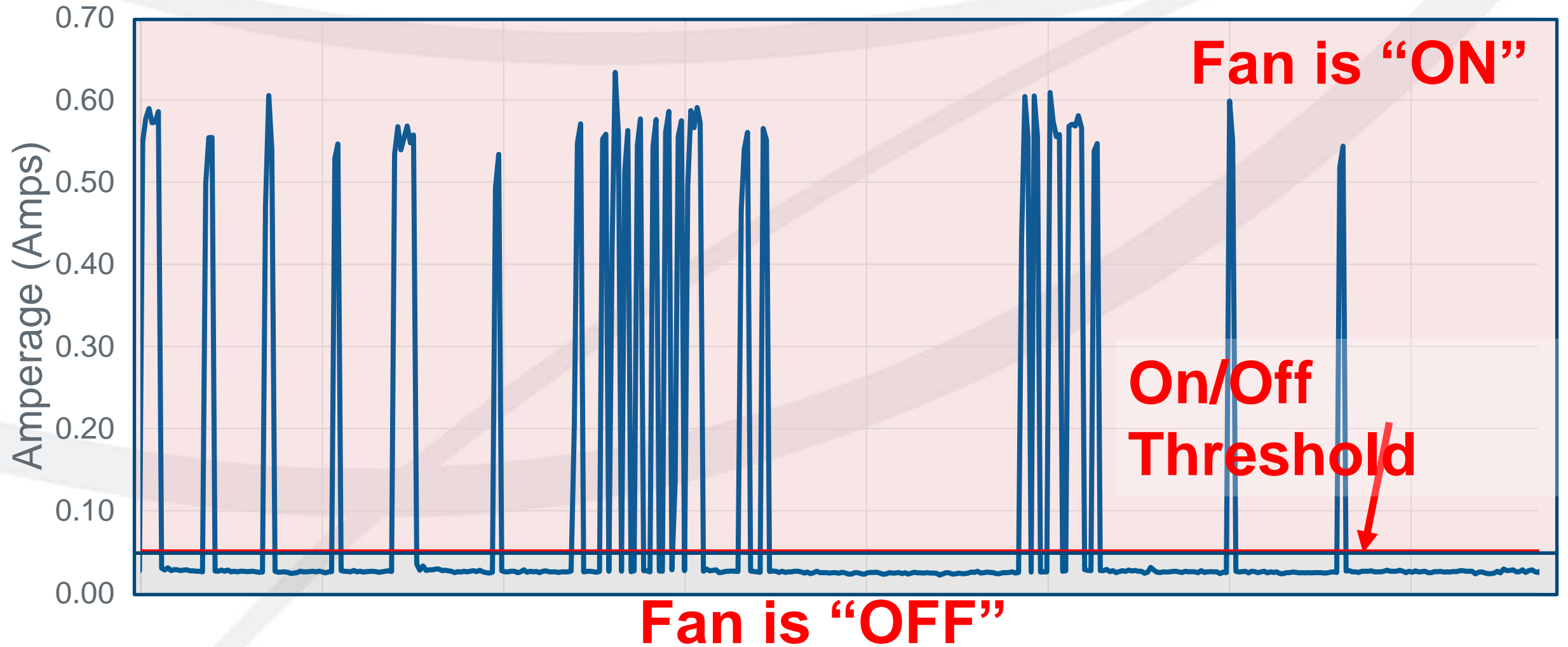

Amps can be converted to Watts and now you know your Base Load!

Watts

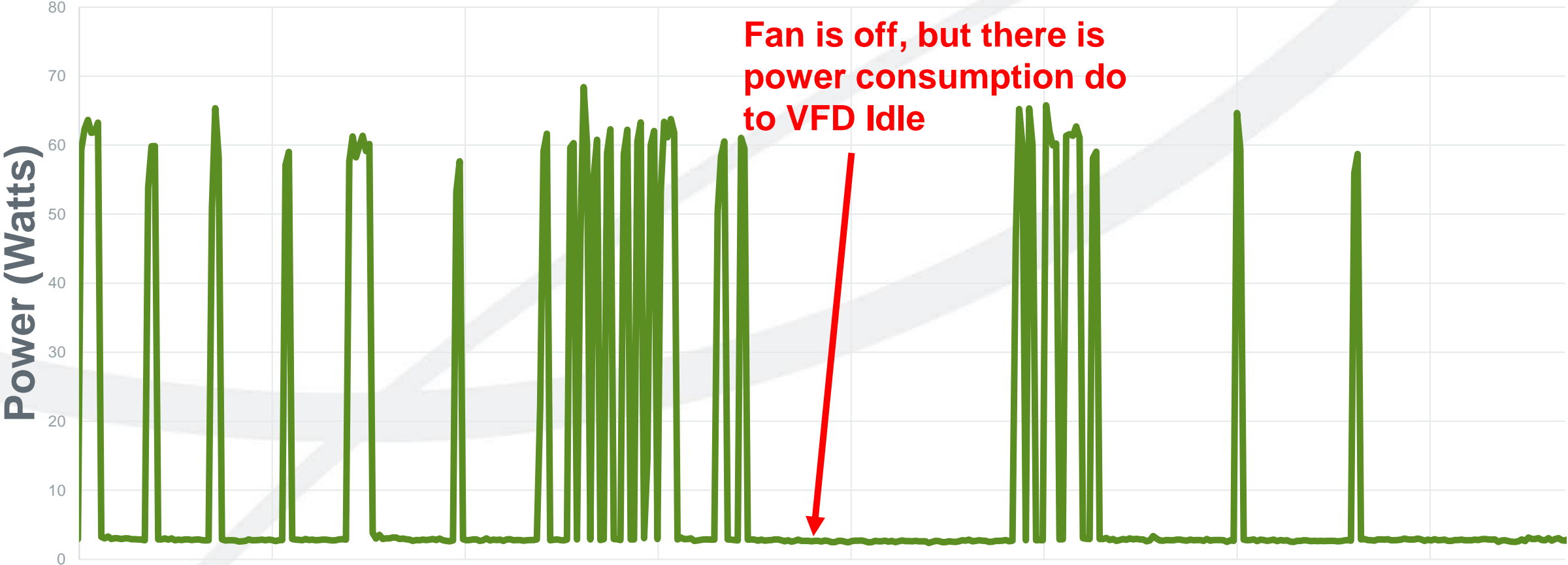

Do you have enough data?

Making Energy Decisions at this resolution will not decarbonize fast enough or cost-effectively in the long run.

ELECTRIC USAGE HISTORY (kWh)

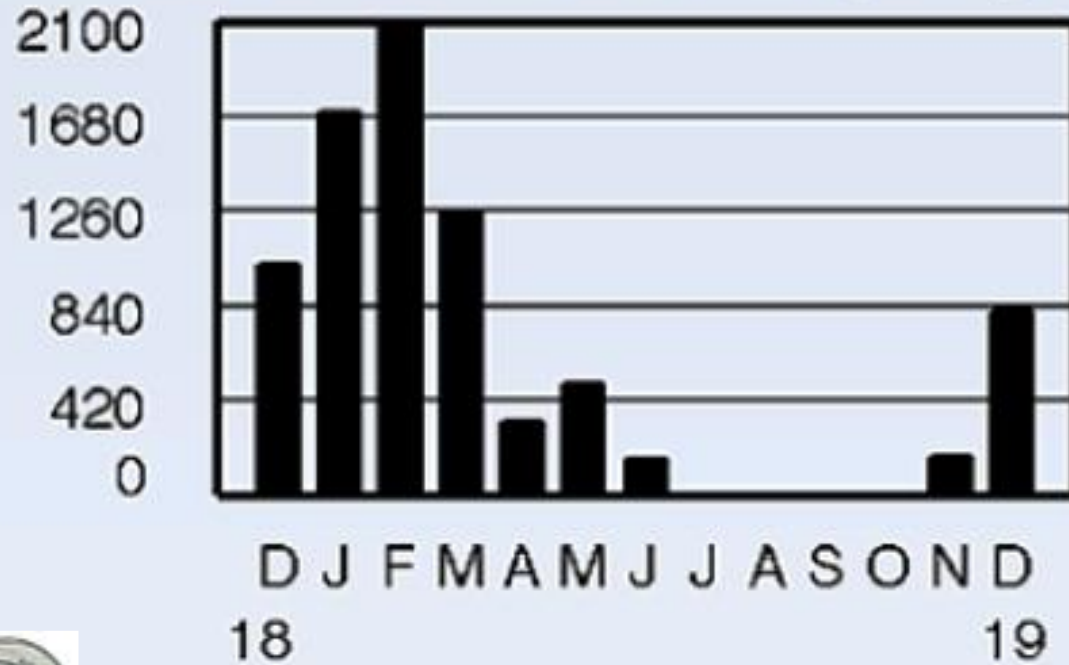

Start here and then take the next step

Energy usage **Increasing meter resolution up gives more actionable data**

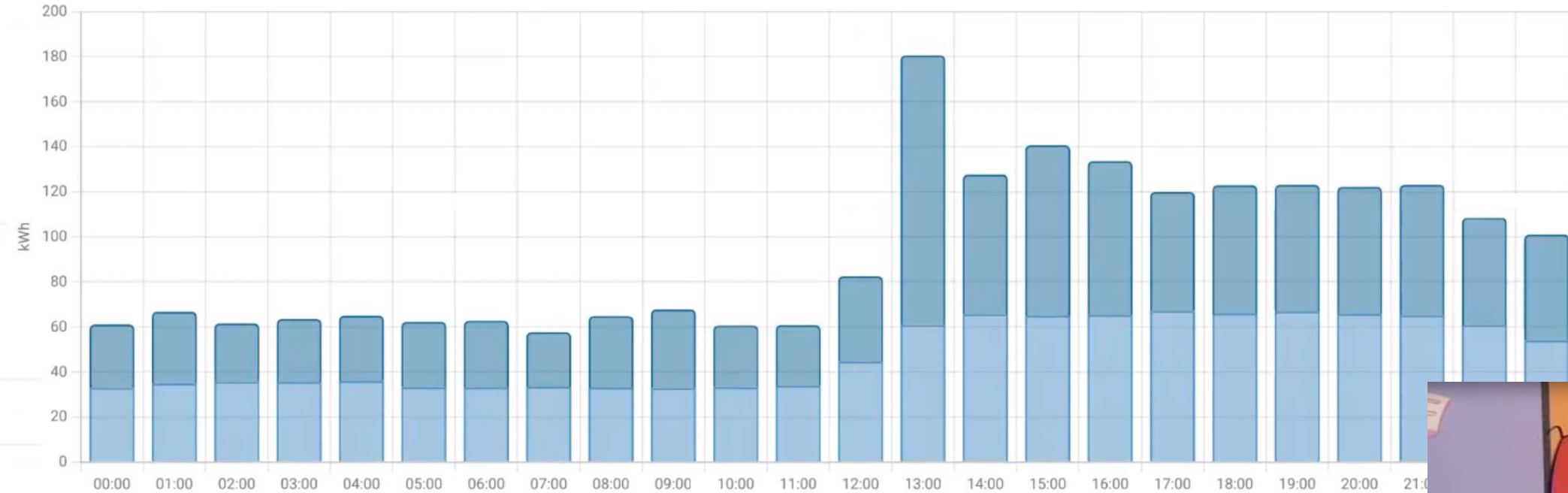

Energy distribution

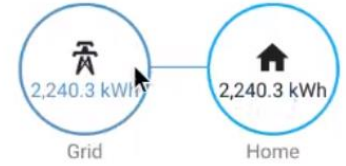

Disaggregation to Uncover Energy Hogs!

Metering at the equipment level lets you find your actual Hogs

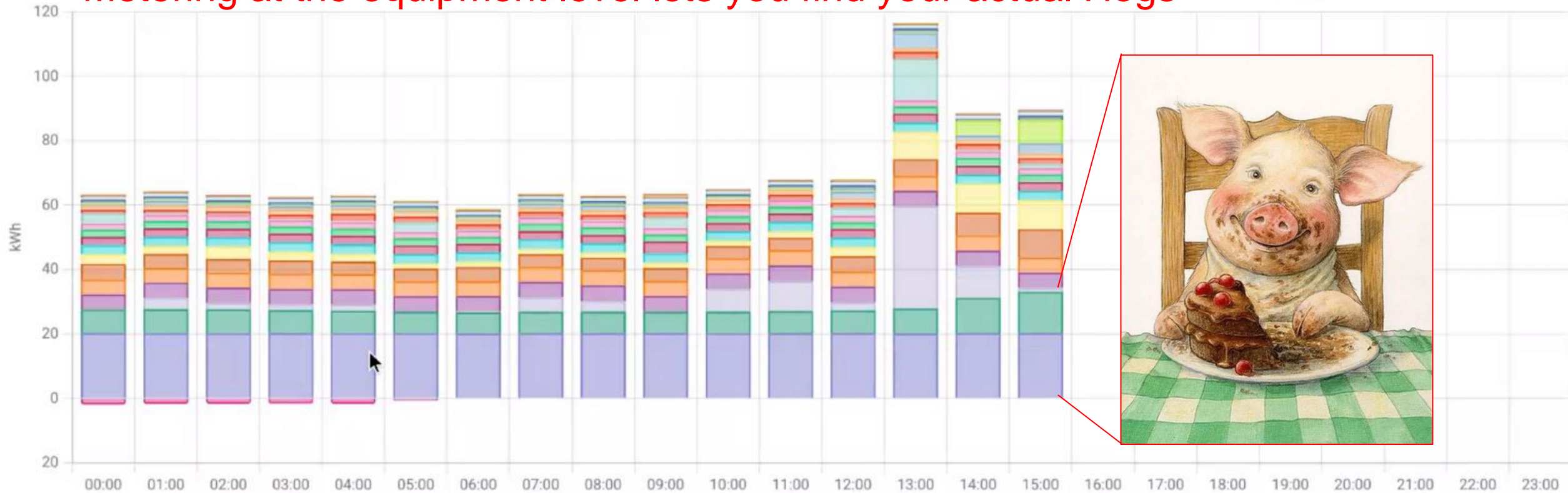

BERDO – Mandatory Reporting leads to fines

- Fines
- **Old Buildings**
- Large Buildings
- 2050 net zero (ratcheting targets)

Year Built Class	Number of buildings			
	Industrial	Commercial	Public & Quasi-Public	Residential (Mixed-Use)
1980-present	43	465	448	467
1950-1979	66	596	189	52
1915-1949	125	1,816	430	451
Pre-1915	73	1,307	1,280	723

BERDO – Mandatory Reporting leads to fines

- Fines
- **Old Buildings**
- Large Buildings
- 2050 net zero (ratcheting targets)

Building Area	Number of buildings			
	Industrial	Commercial	Public & Quasi-Public	Residential (Mixed-Use)
< 25,000 sqft	230	3,426	1,579	1,463
25,000-34,999 sqft	21	178	168	49
35,000-49,999 sqft	19	134	140	41
50,000-99,999 sqft	23	202	212	61
>= 100,000 sqft	14	244	248	79

BERDO – Mandatory Reporting leads to fines

- Fines
- Old Buildings
- **Large Buildings**
- 2050 net zero (ratcheting targets)

Building Area	Number of buildings			
	Industrial	Commercial	Public & Quasi-Public	Residential (Mixed-Use)
< 25,000 sqft	230	3,426	1,579	1,463
25,000-34,999 sqft	21	178	168	49
35,000-49,999 sqft	19	134	140	41
50,000-99,999 sqft	23	202	212	61
>= 100,000 sqft	14	244	248	79

BERDO – Mandatory Reporting leads to fines

- Fines
- Old Buildings
- Large Buildings
- 2050 net zero (ratcheting targets)

(ii) Failure to Comply with Emission Standards.

If a Building Owner did not comply with the applicable Emissions standard in a calendar year, each Day of that calendar year and each subsequent Day when the violation is not corrected shall be deemed a separate violation of this Subsection and subject to a fine of:

1. One thousand dollars (\$1,000) a Day for:
 - a. Non-Residential Buildings equal to or greater than thirty-five thousand (35,000) gross square feet or two (2) or more Buildings on the same parcel that equal or exceed one hundred thousand (100,000) gross square feet; and
 - b. Residential Buildings equal to or greater than thirty-five (35) units or thirty-five thousand (35,000) gross square feet.
2. Three hundred dollars (\$300) a Day for:
 - a. Non-Residential Buildings equal to or greater than twenty thousand (20,000) gross square feet but less than thirty-five thousand (35,000) gross square feet; and
 - b. Residential Buildings equal to or greater than fifteen (15) units or twenty thousand (20,000) gross square feet, but less than thirty-five (35) units or thirty-five thousand (35,000) gross square feet.

An important measurement

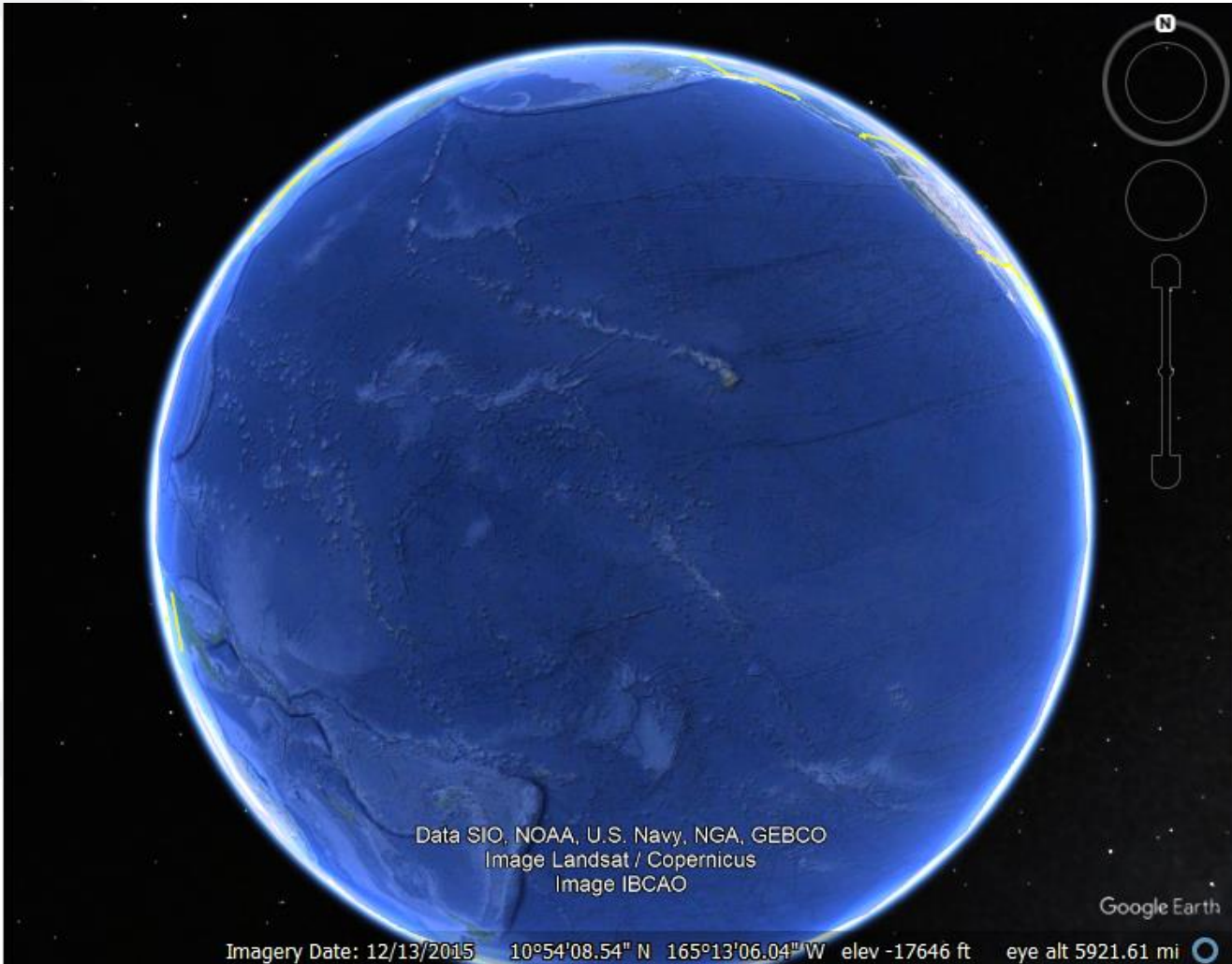

Review

- Part 1 – Introduction / Background
- Part 2 – Reducing Heating Loads
- Part 3 – Electrifying Heating Systems
- Part 4 – Reducing Fan Energy
- Part 5 – The Importance of Intelligent Building Controls

We need equipment *and* controls to successfully decarbonize existing buildings



Contact Form



Mark LaFrance

HTS New England

mark.lafrance@hts.com

Rick Stehmeyer

Control Technologies Inc.

Rick.Stehmeyer@controltechinc.com